

5. Letter designations preceding the part number column are used throughout this catalog to represent the classification of those parts. These letter designations are listed below for ease of interpretation and identification.

NA - Part is Not Available

NSS - Not Sold Separately - Order complete assembly

PT - Available in packages of Twelve Only. Add. suffix 012 to part number when ordering.

6. Compressor models are identified as follows :

A. Capacity control

- 06 EA (No unloaders)
- 06 EB (1 cyl. bank unloaded, elec.)
- 06 EC (2 cyl. banks unloaded, elec.)
- 06 ED (1 cyl. bank unloaded, pres.)
- 06 EF (Reversed Head, No unloaders)
- 06 EJ (Reversed Head, 1 cyl. bank unloaded, elec.)
- 06 EK (Reversed Head, 2 cyl. banks unloaded, elec.)

B. Reversed Head

Certain models are built with a "Reverse" (Rear Discharge Flange) Center Cylinder Head. These models are identified by the letter F, J or K in the fourth digit of the model number. CARRIER s.a. Parts Center will furnish only the standard Replacement Model. When required, the "Reversed" Center Bank Cylinder Head must be removed from the original compressor and used on the Standard Replacement Model.

Ex : Manufactured Model Number with a "Reverse" Cylinder Head may be 06EF299840, The Replacement Model will be 06EX299860.

7. Compressor Assembly-Less Shut-Off Valves and capacity control external components, but with plugged heads, adaptable to either Electric or pressure actuated capacity control. Capacity control Valve must be removed from original Compressor or 06 EX Compressor will operate fully loaded at all times.

LEGEND

1. Motor
2. Motor Key
3. Rotor Plate Washer
4. Rotor Lock Washer
5. Rotor Lock Bolt
6. Motor Lock Bushing
7. Roll Pin
8. Acorn Nut and Gasket
9. Terminal Plate Assembly
10. A. Bolt terminal  
B. Washer Insulation (red)  
C. Washer Insulation (grey)  
D. Bushing seal  
E. Set screw  
F. Clamp wire
11. A. Bolt Assembly  
B. Washer Insulation (red)  
C. Washer Insulation (grey)  
D. Bushing seal  
E. Screw Match Slotted
12. Crankcase
13. Motor end cover
14. Cylinder head-center bank
15. Cylinder head-cap. control side bank
16. Cylinder head capscrew
17. Internal relief valve
18. Crankcase oil filter screen assembly
19. Oil sight glass assembly
20. Oil sight glass "O" ring gasket
21. Oil sight glass Screw 1/4-28 x 7/8
22. Oil sight glass screw lockwasher
23. Hex Hd. Pipe plug gasket
24. Bottom cover plate
25. Pump end Bearing Hd.
26. Pump Rotor
27. Pump vane
28. Pump vane spring
29. Pump vane spring guide
30. Retaining Ring
31. Oil Feed Guide Vane

LEGEND (Cont'd)

32. Oil Feed Guide Vane Spring
33. Oil Pump Drive Segment
34. Socket Head Screw
35. Socket Head Screw
36. Cover plate
37. Cover plate capscrew
38. Oil relief valve piston
39. Crankshaft Assembly
40. Bearing Washer
41. Piston Rings
42. Piston, Piston pin & retaining ring
43. Piston
44. Piston Pin
45. Retaining Ring
46. Connecting Rod and Cap assembly
47. Nylock Capscrew
48. Standard Valve Plate Package
49. Valve Plate
50. Discharge Valve Stop
51. Discharge Valve
52. Valve stop Support
53. Valve stop Capscrew
54. Suction Valve
55. Capacity Control Valve Plate Package
56. Check valve Piston
57. Check valve Spring
58. Check valve Body

SPECIFIED PARTS

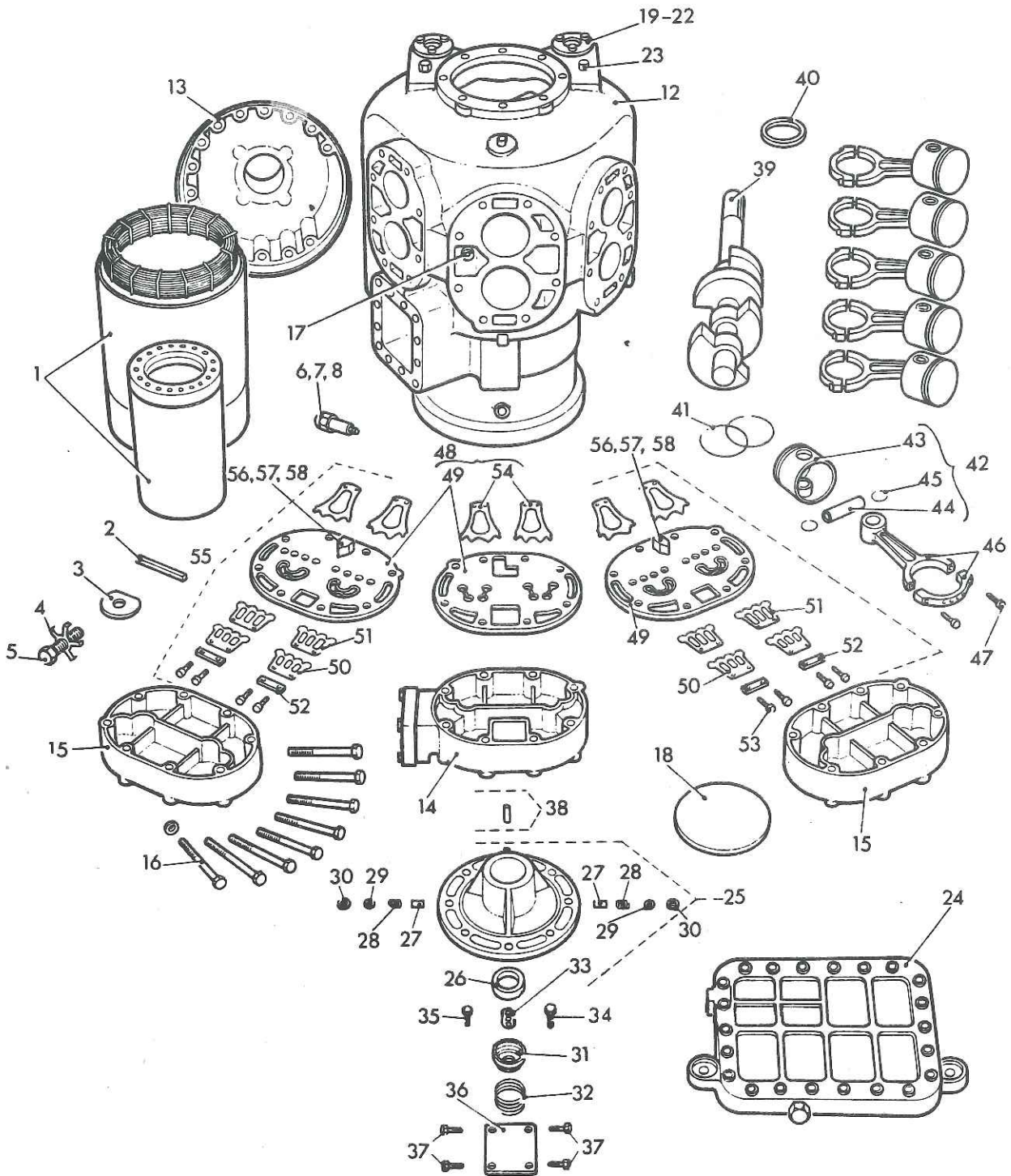

SPECIFIED PARTS

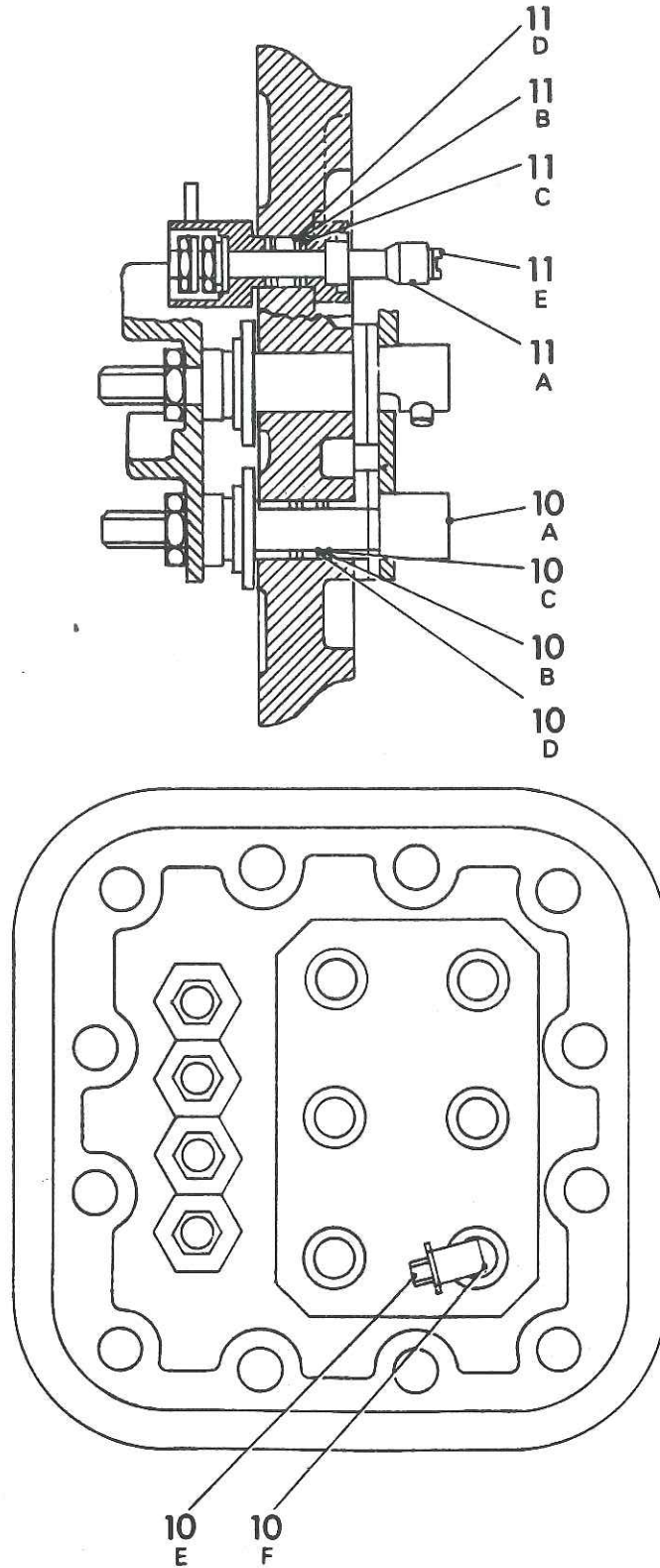

06 EX 150, 175, 250  
265, 275, 299

| I<br>T<br>E<br>M | DESCRIPTION | C<br>O<br>D<br>E | PART-NUMBER | USED ON |     |     |     |     |     |
|------------------|-------------|------------------|-------------|---------|-----|-----|-----|-----|-----|
|                  |             |                  |             | 150     | 175 | 250 | 265 | 275 | 299 |

COMPRESSOR REPLACEMENT

|            |          |  |                      |   |   |   |   |   |  |  |  |  |  |  |  |  |  |  |  |   |
|------------|----------|--|----------------------|---|---|---|---|---|--|--|--|--|--|--|--|--|--|--|--|---|
| Compressor | 230/3/50 |  | 06EX-150---863---E-- | 1 |   |   |   |   |  |  |  |  |  |  |  |  |  |  |  |   |
|            |          |  | 06EX-175---863---E-- |   | 1 |   |   |   |  |  |  |  |  |  |  |  |  |  |  |   |
|            |          |  | 06EX-250---863---E-- |   |   | 1 |   |   |  |  |  |  |  |  |  |  |  |  |  |   |
|            |          |  | 06EX-265---863---E-- |   |   |   | 1 |   |  |  |  |  |  |  |  |  |  |  |  |   |
|            |          |  | 06EX-275---863---E-- |   |   |   |   | 1 |  |  |  |  |  |  |  |  |  |  |  |   |
|            |          |  | 06EX-299---863---E-- |   |   |   |   |   |  |  |  |  |  |  |  |  |  |  |  | 1 |
| Compressor | 400/3/50 |  | 06EX-150---963---E-- | 1 |   |   |   |   |  |  |  |  |  |  |  |  |  |  |  |   |
|            |          |  | 06EX-175---963---E-- |   | 1 |   |   |   |  |  |  |  |  |  |  |  |  |  |  |   |
|            |          |  | 06EX-250---963---E-- |   |   | 1 |   |   |  |  |  |  |  |  |  |  |  |  |  |   |
|            |          |  | 06EX-265---963---E-- |   |   |   | 1 |   |  |  |  |  |  |  |  |  |  |  |  |   |
|            |          |  | 06EX-275---963---E-- |   |   |   |   | 1 |  |  |  |  |  |  |  |  |  |  |  |   |
|            |          |  | 06EX-299---963---E-- |   |   |   |   |   |  |  |  |  |  |  |  |  |  |  |  | 1 |

| I<br>T<br>E<br>M | DESCRIPTION | C<br>O<br>D<br>E | PART-NUMBER | USED ON |     |     |     |     |     |
|------------------|-------------|------------------|-------------|---------|-----|-----|-----|-----|-----|
|                  |             |                  |             | 150     | 175 | 250 | 265 | 275 | 299 |

COMPRESSOR MOTOR REPLACEMENT

|   |                |  |                      |   |   |   |   |   |  |   |  |
|---|----------------|--|----------------------|---|---|---|---|---|--|---|--|
| 1 | Motor 230/3/50 |  | 06EP-645---854---E-- | 1 |   |   |   |   |  |   |  |
|   |                |  | 06EP-675---854---E-- |   | 1 |   |   |   |  |   |  |
|   |                |  | 06EP-660---854---E-- |   |   | 1 |   |   |  |   |  |
|   |                |  | 06EP-675---854---E-- |   |   |   | 1 |   |  |   |  |
|   |                |  | 06EP-690---854---E-- |   |   |   |   | 1 |  |   |  |
|   |                |  | 06EP-612---854---E-- |   |   |   |   |   |  | 1 |  |
| 1 | Motor 400/3/50 |  | 06EP-645---654---E-- | 1 |   |   |   |   |  |   |  |
|   |                |  | 06EP-675---654---E-- |   | 1 |   |   |   |  |   |  |
|   |                |  | 06EP-660---654---E-- |   |   | 1 |   |   |  |   |  |
|   |                |  | 06EP-675---654---E-- |   |   |   | 1 |   |  |   |  |
|   |                |  | 06EP-690---654---E-- |   |   |   |   | 1 |  |   |  |
|   |                |  | 06EP-612---654---E-- |   |   |   |   |   |  | 1 |  |

06 EX

150, 175, 250  
265, 275, 299

| I<br>T<br>E<br>M | DESCRIPTION | C<br>D<br>D<br>E | PART-NUMBER | USED ON |     |     |     |     |     |
|------------------|-------------|------------------|-------------|---------|-----|-----|-----|-----|-----|
|                  |             |                  |             | 150     | 175 | 250 | 265 | 275 | 299 |

REPLACEMENT COMPRESSOR AND MOTOR GROUP

|   |  |  |                      |   |   |   |   |   |   |
|---|--|--|----------------------|---|---|---|---|---|---|
| 1 | Motor Burn-Out Kit   |  | 06EA-660---013--C--- | 1 | 1 | 1 | 1 | 1 | 1 |
| 2 | Motor Key  |  | --AW--01DA-226--C--- |   | 1 |   |   | 1 |   |
|   |  |  | --AW--01DA-224--C--- | 1 |   | 1 | 1 |   |   |
|   |  |  | --AW--01DA-229--C--- |   |   |   |   |   | 1 |
| 3 | Rotor Plate Washer   |  | 06EA-500---171--C--- | 1 | 1 | 1 | 1 | 1 | 1 |
| 4 | Rotor Lock Washer  |  | 06EA-500---141--C--- | 1 | 1 | 1 | 1 | 1 | 1 |
| 5 | Rotor Lock Bolt  |  | 06EA-500---341--C--- | 1 |   | 1 | 1 |   |   |
|   |  |  | 06EA-500---371--C--- |   |   |   |   |   | 1 |
|   |  |  | 06EA-500---351--C--- |   | 1 |   |   | 1 |   |
| 1 | Check Valve, Crankshaft<br>(Must be used on interconnected<br>Compressor Assemblies) |  | -6-D--40---162--C--- | 1 | 1 | 1 | 1 | 1 | 1 |
| 6 | Motor Lock Bushing   |  | 06EA-500---211--C--- | 1 | 1 | 1 | 1 | 1 | 1 |
| 7 | Roll Pin, Motor Lock Bushing<br>(3/8"x2" Lg.)  |  | --AX--14CP-235--C--- | 1 | 1 | 1 | 1 | 1 | 1 |
| 8 | Acorn Nut, Motor Lock (3/4-16)   |  | --AT--27AA-362--C--- | 1 | 1 | 1 | 1 | 1 | 1 |
| 8 | Gasket, Acorn  |  | --AU--51YA-012--C--- | 1 | 1 | 1 | 1 | 1 | 1 |



| I<br>T<br>E<br>M | DESCRIPTION | C<br>O<br>D<br>E | PART-NUMBER | USED ON |     |     |     |     |     |
|------------------|-------------|------------------|-------------|---------|-----|-----|-----|-----|-----|
|                  |             |                  |             | 150     | 175 | 250 | 265 | 275 | 299 |

MOTOR TERMINAL MOUNTING GROUP

|    |   |  |                      |   |             |   |   |   |   |  |
|----|---|--|----------------------|---|-------------|---|---|---|---|--|
| NI | Junction Box  |  | 06EA-500---184--EE-- | 1 | 1           | 1 | 1 | 1 | 1 |  |
| NI | Shield, Low Voltage   |  | 06EA-680---040--C--- |   | As Required |   |   |   |   |  |
| 9  | Terminal Plate Assembly                                     |  | 06EA-660---151--EE-- | 1 | 1           | 1 | 1 | 1 | 1 |  |
| 10 | Terminal Bolt Repair Kit (power)<br>(1 Bolt - 5 Req./unit)  |  | 06EA-660---035--C--- |   | As Required |   |   |   |   |  |
|    | Includes :  |  |                      |   |             |   |   |   |   |  |
|    | Terminal Bolt (1)   |  | 06EA-500---552--C--- |   |             |   |   |   |   |  |
|    | Terminal Plate Gasket (1)                                   |  | -6-G--45--1082--C--- |   |             |   |   |   |   |  |
|    | Washer Seal (red) (2)                                       |  | -6-G--45--1081--C--- |   |             |   |   |   |   |  |
|    | Washer Seal (grey) (2)                                      |  | -6-G--45--1091--C--- |   |             |   |   |   |   |  |
|    | Bushing Seal (1)  |  | -6-G--45--1071--C--- |   |             |   |   |   |   |  |
|    | Nylock Screw (1)  |  | --AE--53AR-166--C--- |   |             |   |   |   |   |  |
|    | Wire Clamp (1)  |  | --HY--78TB-006--C--- |   |             |   |   |   |   |  |
| 11 | Terminal Bolt Repair Kit (sensor)<br>(1 Bolt - 4 Req./unit) |  | 06EA-660---036--C--- |   | As Required |   |   |   |   |  |
|    | Includes :  |  |                      |   |             |   |   |   |   |  |
|    | Terminal Bolt (1)   |  | -6-L-120--251--C---  |   |             |   |   |   |   |  |
|    | Terminal Plate Gasket (1)                                   |  | -6-G--45--1082--C--- |   |             |   |   |   |   |  |
|    | Washer Seal (red) (2)                                       |  | -6-D--40--1081---E-- |   |             |   |   |   |   |  |
|    | Washer Seal (grey) (2)                                      |  | -6-D--40--1091---E-- |   |             |   |   |   |   |  |
|    | Bushing Seal (1)  |  | -6-D--40--1071--C--- |   |             |   |   |   |   |  |
|    | Nylock Screw (1)  |  | --AC--74AA-102--C--- |   |             |   |   |   |   |  |
| NI | Plate, Cover  |  | 06EA-501---844--C--- | 1 | 1           | 1 | 1 | 1 | 1 |  |
| NI | Screw, Hex Hd.  |  | --AB--12AA-132--EE-- | 4 | 4           | 4 | 4 | 4 | 4 |  |

| I<br>T<br>E<br>M | DESCRIPTION | C<br>O<br>D<br>E | PART-NUMBER | USED ON |     |     |     |     |     |
|------------------|-------------|------------------|-------------|---------|-----|-----|-----|-----|-----|
|                  |             |                  |             | 150     | 175 | 250 | 265 | 275 | 299 |

## CAPACITY CONTROL GROUP

NOTE : For the purpose of simplicity, the quantities required in the Model Usage Column have been omitted.  
Quantities required are determined by the Compressor Model. Please refer to § 6.A

|    |  |  |                      |  |  |  |  |  |  |             |
|----|--|--|----------------------|--|--|--|--|--|--|-------------|
| NI | Capacity Control Valve, Electric<br>(Less Coil)                    |  | 06EA-400---583--C--- |  |  |  |  |  |  | As Required |
|    | Includes : Gasket (1)  |  | -6-D--75--2662--C--- |  |  |  |  |  |  |             |
| NI | Capacity Control Coil, Electrical<br>230 V - 1 PH - 50 HZ          |  | 06EA-401---303--C--- |  |  |  |  |  |  | As Required |
| NI | Capacity Control Valve, Pressure                                   |  | 06EA-404---304--C--- |  |  |  |  |  |  | As Required |
|    | Includes : Gasket (1)  |  | -6-D--75--2662--C--- |  |  |  |  |  |  |             |
| NI | Capacity Control Cylinder<br>Head Strainer                         |  | -6-D--75---601--C--- |  |  |  |  |  |  | As Required |
| NI | Power Head Assembly  |  | 06EA-601---133--C--- |  |  |  |  |  |  | As Required |
| NI | Capacity Control Valve Capscrew<br>(3 Req. per Cap. Control Valve) |  | --AB--44AA-168--C--- |  |  |  |  |  |  | As Required |
| NI | Cylinder Head, Side Bank Plugged<br>(Service)                      |  | 06EA-400---313--C--- |  |  |  |  |  |  | As Required |
|    | Includes : Cylinder Head (1)                                       |  | 06EA-500---304--C--- |  |  |  |  |  |  |             |
|    | Plug (1)   |  | 06DA-501---072--C--- |  |  |  |  |  |  |             |
|    | Spring (1)   |  | 06DA-500---061--C--- |  |  |  |  |  |  |             |
|    | Strainer (1)   |  | -6-D--75---601--C--- |  |  |  |  |  |  |             |
|    | Gasket (1)   |  | -6-D--75--2662--C--- |  |  |  |  |  |  |             |
|    | Seat Ring (1)  |  | 06DA-500---051--C--- |  |  |  |  |  |  |             |
|    | Cover Plate (1)  |  | 06DA-501---032--C--- |  |  |  |  |  |  |             |

| I<br>T<br>E<br>M | DESCRIPTION | C<br>O<br>D<br>E | PART-NUMBER | USED ON |     |     |     |     |     |
|------------------|-------------|------------------|-------------|---------|-----|-----|-----|-----|-----|
|                  |             |                  |             | 150     | 175 | 250 | 265 | 275 | 299 |

COMPRESSOR BODY GROUP

|    |                                    |  |                      |    |    |    |    |    |             |
|----|------------------------------------|--|----------------------|----|----|----|----|----|-------------|
| NI | Gasket Set                         |  | 06EA-660---009--C--- | 1  | 1  | 1  | 1  | 1  | 1           |
| 12 | Crankcase Assembly                 |  | 06EA-400---834--C--- |    | 1  |    | 1  | 1  | 1           |
|    | Each Includes :                    |  | 06EA-400---864--C--- | 1  |    | 1  |    |    |             |
|    | Bearing, M.E. (1)                  |  | 06EA-500---362--C--- |    |    |    |    |    |             |
|    | Bearing, Crankcase Side (1)        |  | 06EA-500---352--C--- |    |    |    |    |    |             |
| NI | Crankcase Heaters Package          |  | 06EA-660---001--EE-- |    |    |    |    |    | As Required |
|    | Includes : Crankcase heater (1)    |  | --WM--12BA-002--EE-- |    |    |    |    |    |             |
|    | Packing gland (1)                  |  | --CE--12PA-002--EE-- |    |    |    |    |    |             |
|    | Nut (1)                            |  | --CE--12DA-002--EE-- |    |    |    |    |    |             |
|    | Crankcase heater fastener          |  | 99RC-500---071--EE-- |    |    |    |    |    |             |
| NI | Compressor Foot                    |  | 06EA-500---052---E-- | 1  | 1  | 1  | 1  | 1  | 1           |
| NI | Compressor Foot Screw 3/8-16 x 1"  |  | --AA--06BR-230---E-- | 2  | 2  | 2  | 2  | 2  | 2           |
| NI | Compressor Foot lockwasher 3/8"    |  | --AK--12AA-003--EE-- | 2  | 2  | 2  | 2  | 2  | 2           |
| 13 | Motor End Cover                    |  | 06EA-500---094--C--- |    | 1  |    |    | 1  | 1           |
|    |                                    |  | -6-D--68--1024---E-- | 1  |    | 1  | 1  |    |             |
| NI | Oil Return Orifice Assembly        |  | 06EA-400---982--C--- | 1  | 1  | 1  | 1  | 1  | 1           |
| NI | Spacer, Motor End Cover            |  | 06EA-500---514--C--- |    |    |    |    |    | 1           |
| NI | Motor End Cover Gasket             |  | -6-F--25--1013--C--- | 1  | 1  | 1  | 1  | 1  | 1           |
| NI | Motor End Cover Capscrew           |  |                      |    |    |    |    |    |             |
|    | 7/16-14 x 4 1/2                    |  | --AA--06BR-275--C--- |    |    |    |    |    | 18          |
|    | 7/16-14 x 3 1/2                    |  | --AA--06BR-271--E--  | 18 | 18 | 18 | 18 | 18 |             |
| 14 | Cylinder Head, Std. Center Bank    |  | 06EA-660---161--EE-- |    | 1  |    | 1  | 1  | 1           |
| NI | Cylinder Head, Reverse Center Bank |  | 06EA-660---171--EE-- |    | 1  |    | 1  | 1  | 1           |

06 EX

150, 175, 250  
265, 275, 299

| I<br>T<br>E<br>M | DESCRIPTION | C<br>D<br>D<br>E | PART-NUMBER | USED ON |     |     |     |     |     |
|------------------|-------------|------------------|-------------|---------|-----|-----|-----|-----|-----|
|                  |             |                  |             | 150     | 175 | 250 | 265 | 275 | 299 |

COMPRESSOR BODY GROUP

|  |  |  |                      |    |             |    |    |    |    |
|--|--|--|----------------------|----|-------------|----|----|----|----|
| DENOTES : Discharge Valve located at Motor end of Cylinder Head                      |  |  |                      |    |             |    |    |    |    |
| 15   | Cylinder Head, Std. Side Bank                              |  | 06EA-660---181--EE-- | 1  | 1           |    |    |    |    |
| NI   | Cylinder Head, Capacity Control Side Bank (Less C/C Valve) |  | 06EA-500---304--C--- |    | As Required |    |    |    |    |
| NI   | Cylinder Head Gasket, Side Bank Std.                       |  | 06EA-502---034--C--- |    | As Required |    |    |    |    |
| NI   | Cylinder Head Gasket, Side Bank W/Unloaders                |  | 06EA-502---044--C--- |    | As Required |    |    |    |    |
| NI   | Cylinder Head Gasket, Center Bank                          |  | 06EA-502---044--C--- |    | As Required |    |    |    |    |
| DENOTES : Quantity req. depends on the number of Capacity Control Bank in Operation. |  |  |                      |    |             |    |    |    |    |
| EXAMPLE : 4 Cylinder Compressor with   |  |  |                      |    |             |    |    |    |    |
|  | No Cap. Control uses (2)                                   |  | 06EA-500---044--C--- |    |             |    |    |    |    |
|  | One Cap. Control uses (1)                                  |  | 06EA-500---044--C--- |    |             |    |    |    |    |
|  | (1)  |  | 06EA-500---304--C--- |    |             |    |    |    |    |
| 6 Cylinder Compressor with   |  |  |                      |    |             |    |    |    |    |
|  | No Cap. Control uses (2)                                   |  | 06EA-500---044--C--- |    |             |    |    |    |    |
|  | One Cap. Control uses (1)                                  |  | 06EA-500---044--C--- |    |             |    |    |    |    |
|  | (1)  |  | 06EA-500---054--C--- |    |             |    |    |    |    |
|  | (1)  |  | 06EA-500---304--C--- |    |             |    |    |    |    |
|  | Two Cap. Control uses (2)                                  |  | 06EA-500---304--C--- |    |             |    |    |    |    |
|  | (1)  |  | 06EA-500---054--C--- |    |             |    |    |    |    |
| 16   | Cylinder Head Capscrew, Std and Unloaded 1/2"-13 x 3 3/4   |  | --AA--06BR-302---E-- | 16 | 24          | 16 | 24 | 24 | 24 |
| 17   | Internal relief Valve                                      |  | --EB--51FN-272--C--- | 1  | 1           | 1  | 1  | 1  | 1  |
| 18   | Oil Filter Screen assembly                                 |  | -6-D--40---103--C--- | 1  | 1           | 1  | 1  | 1  | 1  |

| I<br>T<br>E<br>M | DESCRIPTION | C<br>O<br>D<br>E | PART-NUMBER | USED ON |     |     |     |     |     |
|------------------|-------------|------------------|-------------|---------|-----|-----|-----|-----|-----|
|                  |             |                  |             | 150     | 175 | 250 | 265 | 275 | 299 |

COMPRESSOR BODY GROUP

|    |   |  |                      |    |    |    |    |    |    |
|----|---|--|----------------------|----|----|----|----|----|----|
| NI | Oil Filter Screen Suction Tube                |  | 06EA-500---233--C--- | 1  | 1  | 1  | 1  | 1  | 1  |
| NI | Blank-Off Cover Screw 1/4-28 x 7/8"           |  | --AA--06BR-169---E-- | 10 | 10 | 10 | 10 | 10 | 10 |
| NI | Blank-Off Cover Lockwasher 1/4"               |  | --AU--61ML-171--C--- | 7  | 7  | 7  | 7  | 7  | 7  |
| 19 | Oil Sight Glass Assembly                      |  | --KM--39BN-010---E-- | 2  | 2  | 2  | 2  | 2  | 2  |
| 20 | Oil Sight Glass "O" Ring Gasket               |  | --UX--12HA-001--EE-- | 2  | 2  | 2  | 2  | 2  | 2  |
| 21 | Oil Sight Glass Screw 1/4-28 x 7/8"           |  | --AB--06BR-169---E-- | 6  | 6  | 6  | 6  | 6  | 6  |
| 22 | Oil Sight Glass Lockwasher 1/4"               |  | --AU--61ML-171--C--- | 6  | 6  | 6  | 6  | 6  | 6  |
| 23 | Pipe Plug 1/4" Hex Hd.                        |  | --CA--64AA-002--C--- | 3  | 3  | 3  | 3  | 3  | 3  |
| NI | Pipe Plug, Hex Hd. 5/8                        |  | -5-H--40--1141--C--- | 1  | 1  | 1  | 1  | 1  | 1  |
| NI | Suction Strainer assembly (M.E.)              |  | -6-D--68---112--C--- | 1  |    | 1  | 1  |    |    |
|    |   |  | 06EA-400---252--C--- |    | 1  |    |    | 1  | 1  |
| 24 | Bottom Cover Plate                            |  | -6-D--68--1274---E-- | 1  | 1  | 1  | 1  | 1  | 1  |
| NI | Bottom Cover Plate Gasket                     |  | -6-D--68--1043--C--- | 1  | 1  | 1  | 1  | 1  | 1  |
| NI | Bottom Cover Plate Capscrew<br>3/8-16 x 2" PT |  | --AA--06BR-235---E-- | 22 | 22 | 22 | 22 | 22 | 22 |

06 EX

150, 175, 250  
265, 275, 299

| I<br>T<br>E<br>M | DESCRIPTION | C<br>O<br>D<br>E | PART-NUMBER | USED ON |     |     |     |     |     |
|------------------|-------------|------------------|-------------|---------|-----|-----|-----|-----|-----|
|                  |             |                  |             | 150     | 175 | 250 | 265 | 275 | 299 |

COMPRESSOR SHUT-OFF VALVE GROUP

|    |                                    |                     |   |   |   |   |   |   |   |  |
|----|------------------------------------|---------------------|---|---|---|---|---|---|---|--|
| NI | Discharge Shut-Off Valve 1 1/8 ODF | --EN--07AA-348--C-- | 1 |   | 1 |   |   |   |   |  |
|    | Includes :                         |                     |   |   |   |   |   |   |   |  |
|    | Cap (1)                            | --EN--99ZA-006--C-- |   |   |   |   |   |   |   |  |
|    | Cap Gasket (1)                     | --EN--99ZA-103--C-- |   |   |   |   |   |   |   |  |
| NI | Discharge Shut-Off Valve Gasket    | -6-D--40--1131--C-- | 1 |   | 1 |   |   |   |   |  |
| NI | Discharge Shut-Off Valve 1 3/8 ODF | --EN--07EA-039--C-- |   | 1 |   | 1 | 1 |   |   |  |
|    | Includes :                         |                     |   |   |   |   |   |   |   |  |
|    | Cap (1)                            | --EN--99ZA-002--C-- |   |   |   |   |   |   |   |  |
|    | Cap Gasket (1)                     | --EN--99ZA-102--C-- |   |   |   |   |   |   |   |  |
| NI | Discharge Shut-Off Valve 1 5/8 ODF | --EN--07EA-041--C-- |   |   |   |   |   |   | 1 |  |
|    | Includes :                         |                     |   |   |   |   |   |   |   |  |
|    | Cap (1)                            | --EN--99ZA-002--C-- |   |   |   |   |   |   |   |  |
|    | Cap Gasket (1)                     | --EN--99ZA-103--C-- |   |   |   |   |   |   |   |  |
| NI | Discharge Shut-Off Valve Capscrew  | --AA--06BR-297--E-- |   | 4 |   | 4 | 4 |   |   |  |
|    |                                    | --AA--06BR-205--E-- | 2 |   | 2 |   |   |   | 2 |  |
| NI | Discharge Shut-Off Valve Gasket    | -6-D--68--1131--C-- |   | 1 |   | 1 | 1 | 1 |   |  |
| NI | Suction Shut-Off Valve 1 5/8 ODF   | --EN--07EA-041--C-- | 1 |   | 1 |   |   |   |   |  |
|    | Includes :                         |                     |   |   |   |   |   |   |   |  |
|    | Cap (1)                            | --EN--99ZA-002--C-- |   |   |   |   |   |   |   |  |
|    | Cap Gasket (1)                     | --EN--99ZA-103--C-- |   |   |   |   |   |   |   |  |
| NI | Suction Shut-Off Valve 2 1/8 ODF   | --EM--13FA-516--C-- |   | 1 |   | 1 | 1 | 1 |   |  |
|    | Includes :                         |                     |   |   |   |   |   |   |   |  |
|    | Cap (1)                            | --EN--99ZA-009--C-- |   |   |   |   |   |   |   |  |
|    | Cap Gasket (1)                     | --EN--99ZA-117--C-- |   |   |   |   |   |   |   |  |
| NI | Suction Shut-Off Valve Capscrew    | --AA--06BR-335--C-- | 4 | 4 | 4 | 4 | 4 | 4 | 4 |  |
| NI | Suction Shut-Off Valve Gasket      | -6-G--65--1061--C-- | 1 | 1 | 1 | 1 | 1 | 1 | 1 |  |

06 EX

150, 175, 250  
265, 275, 299

| I<br>T<br>E<br>M | DESCRIPTION | C<br>O<br>D<br>E | PART-NUMBER | USED ON |     |     |     |     |     |
|------------------|-------------|------------------|-------------|---------|-----|-----|-----|-----|-----|
|                  |             |                  |             | 150     | 175 | 250 | 265 | 275 | 299 |

COMPRESSOR SHUT-OFF VALVE GROUP

|    |                                    |                     |   |   |   |   |   |   |   |  |
|----|------------------------------------|---------------------|---|---|---|---|---|---|---|--|
| NI | Discharge Shut-Off Valve 1 1/8 ODF | --EN--07AA-348--C-- | 1 |   | 1 |   |   |   |   |  |
|    | Includes :                         |                     |   |   |   |   |   |   |   |  |
|    | Cap (1)                            | --EN--99ZA-006--C-- |   |   |   |   |   |   |   |  |
|    | Cap Gasket (1)                     | --EN--99ZA-103--C-- |   |   |   |   |   |   |   |  |
| NI | Discharge Shut-Off Valve Gasket    | -6-D--40--1131--C-- | 1 |   | 1 |   |   |   |   |  |
| NI | Discharge Shut-Off Valve 1 3/8 ODF | --EN--07EA-039--C-- |   | 1 |   | 1 | 1 |   |   |  |
|    | Includes :                         |                     |   |   |   |   |   |   |   |  |
|    | Cap (1)                            | --EN--99ZA-002--C-- |   |   |   |   |   |   |   |  |
|    | Cap Gasket (1)                     | --EN--99ZA-102--C-- |   |   |   |   |   |   |   |  |
| NI | Discharge Shut-Off Valve 1 5/8 ODF | --EN--07EA-041--C-- |   |   |   |   |   |   | 1 |  |
|    | Includes :                         |                     |   |   |   |   |   |   |   |  |
|    | Cap (1)                            | --EN--99ZA-002--C-- |   |   |   |   |   |   |   |  |
|    | Cap Gasket (1)                     | --EN--99ZA-103--C-- |   |   |   |   |   |   |   |  |
| NI | Discharge Shut-Off Valve Capscrew  | --AA--06BR-297--E-- |   | 4 |   | 4 | 4 |   |   |  |
|    |                                    | --AA--06BR-205--E-- | 2 |   | 2 |   |   |   | 2 |  |
| NI | Discharge Shut-Off Valve Gasket    | -6-D--68--1131--C-- |   | 1 |   | 1 | 1 | 1 |   |  |
| NI | Suction Shut-Off Valve 1 5/8 ODF   | --EN--07EA-041--C-- | 1 |   | 1 |   |   |   |   |  |
|    | Includes :                         |                     |   |   |   |   |   |   |   |  |
|    | Cap (1)                            | --EN--99ZA-002--C-- |   |   |   |   |   |   |   |  |
|    | Cap Gasket (1)                     | --EN--99ZA-103--C-- |   |   |   |   |   |   |   |  |
| NI | Suction Shut-Off Valve 2 1/8 ODF   | --EM--13FA-516--C-- |   | 1 |   | 1 | 1 | 1 |   |  |
|    | Includes :                         |                     |   |   |   |   |   |   |   |  |
|    | Cap (1)                            | --EN--99ZA-009--C-- |   |   |   |   |   |   |   |  |
|    | Cap Gasket (1)                     | --EN--99ZA-117--C-- |   |   |   |   |   |   |   |  |
| NI | Suction Shut-Off Valve Capscrew    | --AA--06BR-335--C-- | 4 | 4 | 4 | 4 | 4 | 4 | 4 |  |
| NI | Suction Shut-Off Valve Gasket      | -6-G--65--1061--C-- | 1 | 1 | 1 | 1 | 1 | 1 | 1 |  |

| I<br>T<br>E<br>M | DESCRIPTION | C<br>O<br>D<br>E | PART-NUMBER | USED ON |     |     |     |     |     |
|------------------|-------------|------------------|-------------|---------|-----|-----|-----|-----|-----|
|                  |             |                  |             | 150     | 175 | 250 | 265 | 275 | 299 |

PUMP END GROUP

|     |                                |  |                      |   |   |   |   |   |   |  |
|-----|--------------------------------|--|----------------------|---|---|---|---|---|---|--|
| 125 | Pump End Bearing Head Package  |  | 06EA-660---001--C--- | 1 | 1 | 1 | 1 | 1 | 1 |  |
|     | Includes :                     |  |                      |   |   |   |   |   |   |  |
| 126 | P.E. Brg. Hd. Gaskets (1)      |  | 06EA-500---002--C--- |   |   |   |   |   |   |  |
| 127 | Pump Rotor (1)                 |  | -6-D--40--1041--C--- |   |   |   |   |   |   |  |
| 128 | Pump Vane (2)                  |  | -6-D--40--1051--C--- |   |   |   |   |   |   |  |
| 129 | Pump Vane Spring (2)           |  | -6-D--40--1031--C--- |   |   |   |   |   |   |  |
| 130 | Pump Vane Spring guide (2)     |  | -6-D--40--1181--C--- |   |   |   |   |   |   |  |
| 131 | Retaining Ring (1)             |  | --AU--47AA-050--C--- |   |   |   |   |   |   |  |
| 132 | Oil Feed Guide Vane (1)        |  | -6-D--40--1171--C--- |   |   |   |   |   |   |  |
| 133 | Oil Feed Guide Vane Spring (1) |  | -6-D--40--1112--E--  |   |   |   |   |   |   |  |
| 134 | Lockwasher 1/2" (1)            |  | --AU--61ML-171--C--- |   |   |   |   |   |   |  |
| 135 | 10 (1)                         |  | --AU--61ML-131--C--- |   |   |   |   |   |   |  |
| 136 | Oil Pump Drive Segment (1)     |  | -6-D--40--1191--E--  |   |   |   |   |   |   |  |
| 137 | Screw Soc. Hd 1/4-28 x 5/8 (1) |  | --AB--44AA-167--E--  |   |   |   |   |   |   |  |
| 138 | Screw Soc. Hd 10-37 x 1/2 (1)  |  | --AB--44AA-126--E--  |   |   |   |   |   |   |  |
| 139 | Cover Plate (1)                |  | -7-J--1--6002--E-Z   |   |   |   |   |   |   |  |
| 140 | Cover Plate Gasket (1)         |  | -6-D--40--1061--C--- |   |   |   |   |   |   |  |
| 141 | Capscrew, Cover Plate (4)      |  | --AA--06BR-199--E--  |   |   |   |   |   |   |  |
| 142 | Oil Relief Valve Piston (1)    |  |                      |   |   |   |   |   |   |  |
|     | Includes :                     |  |                      |   |   |   |   |   |   |  |
| 143 | Piston (1)                     |  | -6-D--40--1241--C--- |   |   |   |   |   |   |  |
| 144 | Spring (1)                     |  | -6-D--40--1251--C--- |   |   |   |   |   |   |  |
| 145 | Cotter Pin (2)                 |  | --AX--01JA-007--C--- |   |   |   |   |   |   |  |
| 146 | Body (1)                       |  | 06EA-500---091--C--- |   |   |   |   |   |   |  |



| I<br>T<br>E<br>M | DESCRIPTION | C<br>O<br>D<br>E | PART-NUMBER | USED ON |     |     |     |     |     |
|------------------|-------------|------------------|-------------|---------|-----|-----|-----|-----|-----|
|                  |             |                  |             | 150     | 175 | 250 | 265 | 275 | 299 |

CRANKSHAFT AND PISTON GROUP

|    |   |     |                      |   |   |   |   |   |   |   |
|----|---|-----|----------------------|---|---|---|---|---|---|---|
| 39 | Crankshaft Assembly   |     | 06EA-400---032--C--- | 1 |   | 1 |   |   |   |   |
|    |   |     | 06EA-400---022--C--- |   | 1 |   |   | 1 |   |   |
|    |   |     | 06EA-660---242--EE-- |   |   |   |   |   |   | 1 |
|    |   |     | 06EA-660---252--EE-- |   |   |   | 1 |   |   |   |
| 41 | Crankshaft Spirol Pin<br>(Bearing Washer Lockpin)   |     | --AX--13AA-091--C--- | 1 | 1 | 1 | 1 | 1 | 1 | 1 |
| 40 | Bearing Washer<br>(Crankshaft to Crankcase M.E.)  |     | 06EA-500---101--C--- | 1 | 1 | 1 | 1 | 1 | 1 | 1 |
| 41 | Piston Ring Package (Oil)<br>(Comp.)  |     | 06EA-660---010--C--- | 4 | 6 | 4 | 6 | 6 | 6 | 6 |
|    | Each includes 12 Rings.<br>(quantities listed are number of<br>rings required per compressor) |     | 06EA-660---011--C--- | 4 | 6 | 4 | 6 | 6 | 6 | 6 |
| 42 | Piston, Piston Pin and Retaining<br>Ring Package  |     | 06EA-660---025--C--- | 4 | 6 | 4 |   | 6 | 6 |   |
|    | Includes :  |     | 06EA-660---056--C--- |   |   |   | 6 |   |   |   |
| 43 | Piston (1)  | NSS |                      |   |   |   |   |   |   |   |
| 44 | Piston Pin (1)  | NSS |                      |   |   |   |   |   |   |   |
| 45 | Retaining Ring (2)  | NSS |                      |   |   |   |   |   |   |   |
| 46 | Connecting Rod and Cap Assembly   |     | 06EA-660---034--C--- | 4 | 6 | 4 | 6 | 6 |   |   |
|    | Each includes :   |     | 06EA-660---026--C--- |   |   |   |   |   |   | 6 |
|    | Nylock Capscrew (2)   |     | 06EA-501---073--C--- |   |   |   |   |   |   |   |

| I<br>T<br>E<br>M | DESCRIPTION | C<br>O<br>D<br>E | PART-NUMBER | USED ON |     |     |     |     |     |
|------------------|-------------|------------------|-------------|---------|-----|-----|-----|-----|-----|
|                  |             |                  |             | 150     | 175 | 250 | 265 | 275 | 299 |

VALVE PLATE GROUP

|    |  |     |                      |   |   |   |   |   |   |   |             |   |   |   |   |   |   |   |
|----|--|-----|----------------------|---|---|---|---|---|---|---|-------------|---|---|---|---|---|---|---|
| 48 | Valve Plate Package (Standard)                                 |     | 06EA-660---047--C--- |   |   |   |   |   |   |   | As Required |   |   |   |   |   |   |   |
|    | Includes :   |     |                      |   |   |   |   |   |   |   |             |   |   |   |   |   |   |   |
| 49 | Valve Plate  | (1) | NSS                  |   |   |   |   |   |   |   |             |   |   |   |   |   |   |   |
| 50 | Discharge Valve Pkg  | (1) | 06EA-660---058--C--- |   |   |   |   |   |   |   |             |   |   |   |   |   |   |   |
|    | Consisting of :  |     |                      |   |   |   |   |   |   |   |             |   |   |   |   |   |   |   |
|    | Discharge Valve Stop   | (2) | 06EA-500---682--C--- |   |   |   |   |   |   |   |             |   |   |   |   |   |   |   |
| 51 | Discharge Valve  | (2) | 06EA-501---363--C--- |   |   |   |   |   |   |   |             |   |   |   |   |   |   |   |
| 52 | Valve Stop Supt.   | (2) | 06EA-500---091--C--- |   |   |   |   |   |   |   |             |   |   |   |   |   |   |   |
| 53 | Capscrew, Valve Stop   | (4) | --AB--06FB-16B--C--- |   |   |   |   |   |   |   |             |   |   |   |   |   |   |   |
|    | Anaerobic resin or equivalent<br>must be used after reassembly |     |                      |   |   |   |   |   |   |   |             |   |   |   |   |   |   |   |
| NI | Lockwasher, Spg 1/4"   | (4) | --AU--61ML-171--C--- |   |   |   |   |   |   |   |             |   |   |   |   |   |   |   |
| NI | Cylinder Head Gasket   | (1) | 06EA-503---314--C--- |   |   |   |   |   |   |   |             |   |   |   |   |   |   |   |
| 54 | Suction Valve Package  | (1) | 06EA-660---057--C--- |   |   |   |   |   |   |   |             |   |   |   |   |   |   |   |
|    | Consisting of :  |     |                      |   |   |   |   |   |   |   |             |   |   |   |   |   |   |   |
|    | Suction Valves   | (4) | 06EA-501---053--C--- |   |   |   |   |   |   |   |             |   |   |   |   |   |   |   |
| NI | Dowel Pins   | (4) | 06EA-501---012--C--- |   |   |   |   |   |   |   |             |   |   |   |   |   |   |   |
| NI | Valve Plate Gasket   | (1) | 06EA-501---063--C--- |   |   |   |   |   |   |   |             |   |   |   |   |   |   |   |
| NI | Cylinder Head Gasket   | (1) | 06EA-503---304--C--- |   |   |   |   |   |   |   |             |   |   |   |   |   |   |   |
| 55 | Valve Plate Pkg (capacity control)                             |     | 06EA-660---048--C--- |   |   |   |   |   |   |   |             |   |   |   |   |   |   |   |
|    | Includes :   |     |                      |   |   |   |   |   |   |   |             |   |   |   |   |   |   |   |
|    | Valve Plate  | (1) | NSS                  |   |   |   |   |   |   |   |             |   |   |   |   |   |   |   |
|    | Washer   |     | 06EA-500---992--C--- | 1 | 1 | 1 | 1 | 1 | 1 | 1 | 1           | 1 | 1 | 1 | 1 | 1 | 1 | 1 |
|    | Capscrew   |     | --AB--44BR-164--C--- | 1 | 1 | 1 | 1 | 1 | 1 | 1 | 1           | 1 | 1 | 1 | 1 | 1 | 1 | 1 |

| I<br>T<br>E<br>M | DESCRIPTION | C<br>O<br>D<br>E | PART-NUMBER | USED ON |     |     |     |     |     |
|------------------|-------------|------------------|-------------|---------|-----|-----|-----|-----|-----|
|                  |             |                  |             | 150     | 175 | 250 | 265 | 275 | 299 |

VALVE PLATE GROUP

|    |   |     |                      |   |   |   |   |   |   |   |   |             |
|----|---|-----|----------------------|---|---|---|---|---|---|---|---|-------------|
| 48 | Valve Plate Package (Standard)                              |     | 06EA-660---047--C--- |   |   |   |   |   |   |   |   | As Required |
|    | Includes :  |     |                      |   |   |   |   |   |   |   |   |             |
| 49 | Valve Plate (1)   | NSS |                      |   |   |   |   |   |   |   |   |             |
| 50 | Discharge Valve Pkg (1)                                     |     | 06EA-660---058--C--- |   |   |   |   |   |   |   |   |             |
|    | Consisting of :   |     |                      |   |   |   |   |   |   |   |   |             |
|    | Discharge Valve Stop (2)                                    |     | 06EA-500---682--C--- |   |   |   |   |   |   |   |   |             |
| 51 | Discharge Valve (2)   |     | 06EA-501---363--C--- |   |   |   |   |   |   |   |   |             |
| 52 | Valve Stop Supt. (2)  |     | 06EA-500---091--C--- |   |   |   |   |   |   |   |   |             |
| 53 | Capscrew, Valve Stop (4)                                    |     | --AB--06FB-16B--C--- |   |   |   |   |   |   |   |   |             |
|    | Anaerobic resin or equivalent must be used after reassembly |     |                      |   |   |   |   |   |   |   |   |             |
| NI | Lockwasher, Spg 1/4" (4)                                    |     | --AU--61ML-171--C--- |   |   |   |   |   |   |   |   |             |
| NI | Cylinder Head Gasket (1)                                    |     | 06EA-503---314--C--- |   |   |   |   |   |   |   |   |             |
| 54 | Suction Valve Package (1)                                   |     | 06EA-660---057--C--- |   |   |   |   |   |   |   |   |             |
|    | Consisting of :   |     |                      |   |   |   |   |   |   |   |   |             |
|    | Suction Valves (4)  |     | 06EA-501---053--C--- |   |   |   |   |   |   |   |   |             |
| NI | Dowel Pins (4)  |     | 06EA-501---012--C--- |   |   |   |   |   |   |   |   |             |
| NI | Valve Plate Gasket (1)                                      |     | 06EA-501---063--C--- |   |   |   |   |   |   |   |   |             |
| NI | Cylinder Head Gasket (1)                                    |     | 06EA-503---304--C--- |   |   |   |   |   |   |   |   |             |
| 55 | Valve Plate Pkg (capacity control)                          |     | 06EA-660---048--C--- |   |   |   |   |   |   |   |   | As Required |
|    | Includes :  |     |                      |   |   |   |   |   |   |   |   |             |
|    | Valve Plate (1)   | NSS |                      |   |   |   |   |   |   |   |   |             |
|    | Washer  |     | 06EA-500---992--C--- | 1 | 1 | 1 | 1 | 1 | 1 | 1 | 1 |             |
|    | Capscrew  |     | --AB--44BR-164--C--- | 1 | 1 | 1 | 1 | 1 | 1 | 1 | 1 |             |

| I<br>T<br>E<br>M | DESCRIPTION | C<br>O<br>D<br>E | PART-NUMBER | USED ON |     |     |     |     |     |
|------------------|-------------|------------------|-------------|---------|-----|-----|-----|-----|-----|
|                  |             |                  |             | 150     | 175 | 250 | 265 | 275 | 299 |

VALVE PLATE GROUP

|    |  |     |                      |   |   |   |   |   |   |   |             |   |   |   |   |   |   |             |
|----|--|-----|----------------------|---|---|---|---|---|---|---|-------------|---|---|---|---|---|---|-------------|
| 48 | Valve Plate Package (Standard)                                 |     | 06EA-660---047--C--- |   |   |   |   |   |   |   | As Required |   |   |   |   |   |   |             |
|    | Includes :   |     |                      |   |   |   |   |   |   |   |             |   |   |   |   |   |   |             |
| 49 | Valve Plate  | (1) | NSS                  |   |   |   |   |   |   |   |             |   |   |   |   |   |   |             |
| 50 | Discharge Valve Pkg  | (1) | 06EA-660---058--C--- |   |   |   |   |   |   |   |             |   |   |   |   |   |   |             |
|    | Consisting of :  |     |                      |   |   |   |   |   |   |   |             |   |   |   |   |   |   |             |
|    | Discharge Valve Stop   | (2) | 06EA-500---682--C--- |   |   |   |   |   |   |   |             |   |   |   |   |   |   |             |
| 51 | Discharge Valve  | (2) | 06EA-501---363--C--- |   |   |   |   |   |   |   |             |   |   |   |   |   |   |             |
| 52 | Valve Stop Supt.   | (2) | 06EA-500---091--C--- |   |   |   |   |   |   |   |             |   |   |   |   |   |   |             |
| 53 | Capscrew, Valve Stop   | (4) | --AB--06FB-16B--C--- |   |   |   |   |   |   |   |             |   |   |   |   |   |   |             |
|    | Anaerobic resin or equivalent<br>must be used after reassembly |     |                      |   |   |   |   |   |   |   |             |   |   |   |   |   |   |             |
| NI | Lockwasher, Spg 1/4"   | (4) | --AU--61ML-171--C--- |   |   |   |   |   |   |   |             |   |   |   |   |   |   |             |
| NI | Cylinder Head Gasket   | (1) | 06EA-503---314--C--- |   |   |   |   |   |   |   |             |   |   |   |   |   |   |             |
| 54 | Suction Valve Package  | (1) | 06EA-660---057--C--- |   |   |   |   |   |   |   |             |   |   |   |   |   |   |             |
|    | Consisting of :  |     |                      |   |   |   |   |   |   |   |             |   |   |   |   |   |   |             |
|    | Suction Valves   | (4) | 06EA-501---053--C--- |   |   |   |   |   |   |   |             |   |   |   |   |   |   |             |
| NI | Dowel Pins   | (4) | 06EA-501---012--C--- |   |   |   |   |   |   |   |             |   |   |   |   |   |   |             |
| NI | Valve Plate Gasket   | (1) | 06EA-501---063--C--- |   |   |   |   |   |   |   |             |   |   |   |   |   |   |             |
| NI | Cylinder Head Gasket   | (1) | 06EA-503---304--C--- |   |   |   |   |   |   |   |             |   |   |   |   |   |   |             |
| 55 | Valve Plate Pkg (capacity control)                             |     | 06EA-660---048--C--- |   |   |   |   |   |   |   |             |   |   |   |   |   |   | As Required |
|    | Includes :   |     |                      |   |   |   |   |   |   |   |             |   |   |   |   |   |   |             |
|    | Valve Plate  | (1) | NSS                  |   |   |   |   |   |   |   |             |   |   |   |   |   |   |             |
|    | Washer   |     | 06EA-500---992--C--- | 1 | 1 | 1 | 1 | 1 | 1 | 1 | 1           | 1 | 1 | 1 | 1 | 1 | 1 | 1           |
|    | Capscrew   |     | --AB--44BR-164--C--- | 1 | 1 | 1 | 1 | 1 | 1 | 1 | 1           | 1 | 1 | 1 | 1 | 1 | 1 | 1           |