

COMPRESSOR/CONDENSING UNITS

(CARRIER) **5H**
FREON

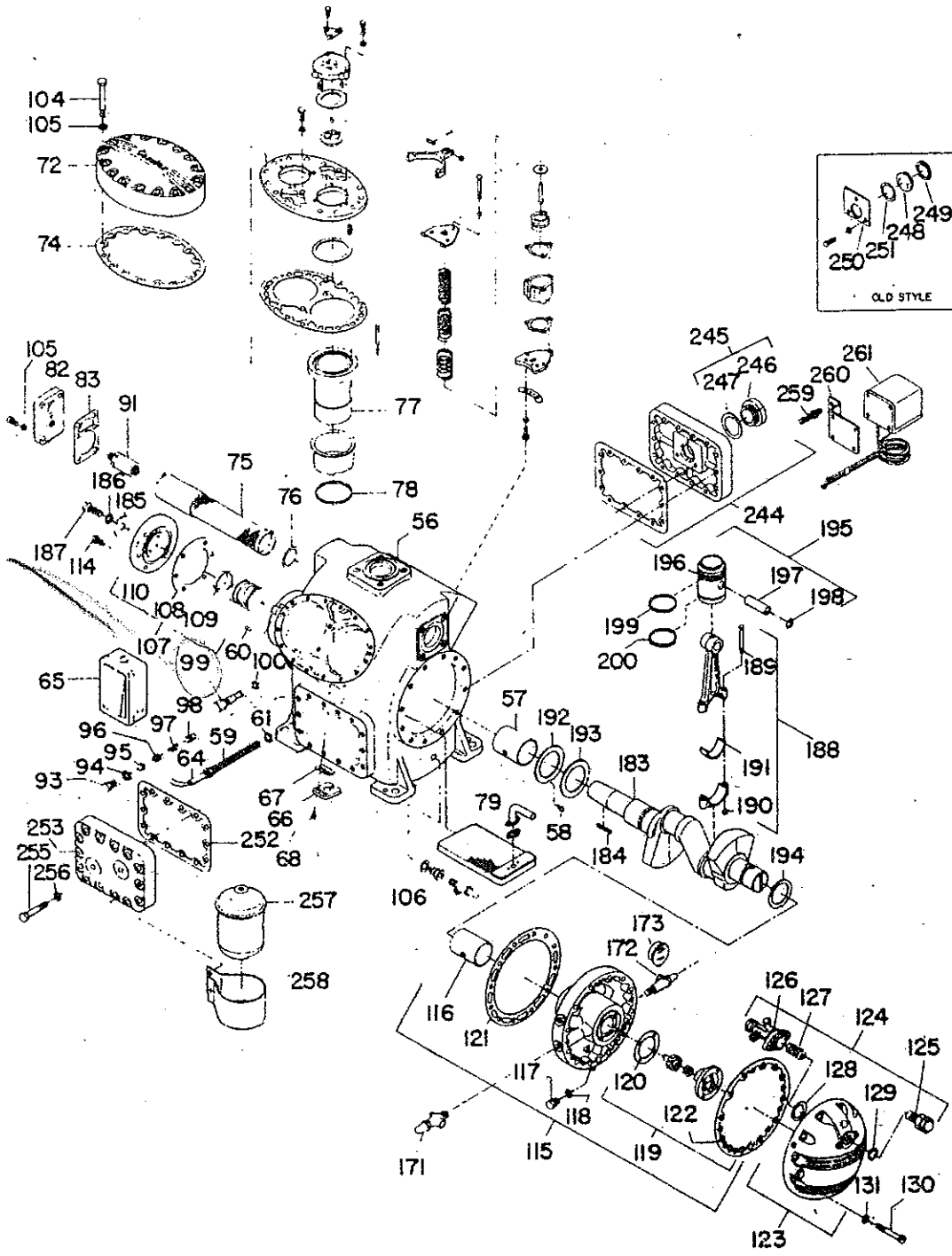

COMPRESSOR
(5H40 shown)



COMPRESSOR/CONDENSING UNITS

5H
FREON

LEGEND 5H40

ITEM NO.	PART NAME	ITEM NO.	PART NAME
56.	Crankcase Assembly	124.	Control Valve Package
57.	Main Bearing	125.	External Valve Assembly
58.	Grove Pin	126.	Valve Body w/Bellows
59.	Heater Casing	127.	Spring
60.	Dowel Pin	128.	Valve Gasket Inner
61.	Magnetic Plug	129.	Valve Gasket Outer
64.	Crankcase Heater Element	130.	Socket Head Capscrew
65.	Crankcase Heater Relay	131.	Capscrew Gasket
66.	Oil Return Check Valve	171.	Double Branch Angle Valve
67.	Check Valve Gasket	172.	Angle Valve
68.	Check Valve Screw, Self Tapping	173.	Oil Pressure Gauge
72.	Cylinder Head	183.	Crankshaft
74.	Cylinder Head Gasket	184.	Flywheel Drive Key
75.	Suction Strainer Assembly	185.	Flywheel Washer
76.	Suction Strainer Gasket	186.	Flywheel Lockwasher
77.	Cylinder Sleeve	187.	Flywheel Capscrew
78.	Cylinder Sleeve Snap Ring	188.	Connecting Rod Package
79.	Oil Screeen Package	189.	Connecting Rod Bolt
82.	Manifold Cover	190.	Connecting Rod Nut
83.	Manifold Cover Gasket	191.	Connecting Rod Bearing Half
91.	Internal Relief Valve	192.	Seal End Bearing Washer
93.	Oil By-Pass Plug	193.	Seal End Trust Washer
94.	Oil By-Pass Plug Gasket	194.	Pump End Bearing Washer
95.	Oil By-Pass Lockscrew	195.	Piston and Pin Assembly
96.	Oil By-Pass Adjusting Screw	196.	Piston
97.	Oil By-Pass Spring	197.	Piston Pin
98.	Oil By-Pass Valve	198.	Piston Pin Lock Ring
99.	Non-Adjustable Oil Pressure Reg. Pkg.	199.	Piston Ring - Oil
100.	Gasket	200.	Piston Ring - Compression
104.	Cylinder Head Capscrew	244.	Hand Hole Cover and Sight Glass Assembly
105.	Cylinder Head Capscrew Gasket	245.	Sight Glass Package
106.	Angle Valve	246.	Sight Glass
107.	Replacement Seal Package	247.	Sight Glass Gasket
108.	Cover Plate Gasket	248.	Sight Glass
109.	Carbon Washer	249.	Inner Gasket
110.	Cover Plate	250.	Sight Glass Clamping Guard
114.	Capscrew	251.	Outer Gasket
115.	Bearing Head and Oil Pump Assembly.	252.	Hand Hole Cover Gasket
116.	Main Bearing	253.	Hand Hole Cover Plain
117.	Magnetic Plug	255.	Capscrew
118.	Plug Gasket	256.	Capscrew Gasket
119.	Oil Pump Package	257.	Oil Filter
120.	Pump Cover Gasket	258.	Oil Filter Bracket
121.	Bearing Head Gasket	259.	Control Bracket Stud
122.	Pump End Gasket	260.	Pressure Control Bracket
123.	Pump End Cover and Control Valve Assy.	261.	Pressurestat



COMPRESSOR/CONDENSING UNITS

5H
FREON

LEGEND 5H120

ITEM NO.	PART NAME	ITEM NO.	PART NAME
61.	Heater Casing and Adapter Gasket	165.	Capscrew Gasket
62.	Oil By-Pass Plug	166.	Oil By-Pass Plug
63.	Plug Gasket	167.	Capacity Control Valve Package
64.	Crankcase Heater Element	168.	Control Valve Gasket
69.	Center Bearing	169.	Capscrew
70.	Center Bearing, Top Half	170.	Capscrew Gasket
71.	Center Bearing, Housing	174.	Oil Filter Cartridge
73.	Cylinder Head, Centerbank	175.	Oil Filter Cover Gasket
80.	Oil Screen and Suction Tube Assembly	176.	Oil Filter Spring
81.	Oil Suction Tube Gasket	177.	Oil Filter Housing
84.	Suction Manifold	178.	Oil Filter Housing Gasket
85.	Suction Manifold Cover	179.	Socket Head Capscrew
86.	Suction Manifold and Cover Gasket	180.	Capscrew Gasket
87.	Discharge Manifold	181.	Oil Filter Cover
88.	Discharge Manifold Gasket	182.	Oil Filter Spring Retainer
89.	Hex Head Capscrew	201.	Oil Recovery Impeller
90.	Capscrew Gasket	202.	Dowel Pin
92.	Pressure Relief Valve,	203.	Valve Plate Package
101.	Oil Pressure Regulator Valve	204.	Valve Plate
102.	Regulator Valve Gasket	205.	Valve Plate Gasket
103.	Regulator Valve Cap	206.	Suction Valve
104.	Cylinder Head Capscrew	207.	Suction Valve Spring
105.	Capscrew Gasket	208.	Lockwasher
111.	Replacement Seal Package	209.	Screw
112.	Cover Plate Gasket	210.	Discharge Valve Guide
113.	Carbon Washer	211.	Lockplate
132.	Bearing Head and Oil Pump Assembly	212.	Guide
133.	Main Bearing	213.	Discharge Valve
134.	Grove Pin	214.	Discharge Valve Spring
135.	Adapter Plug	215.	Screw
136.	Control Oil Strainer	216.	Dowel Pin 3/16"
137.	Oil Filter By-Pass Spring	217.	Dowel Pin 1/4"
138.	By-Pass Retaining Ring	218.	Capscrew
139.	Valve Disc, By-Pass and Equalizer	219.	Capscrew Gasket
140.	Angle Valve	220.	Unloader Sleeve
141.	Hydraulic Relay	221.	Valve Lifter Spring
142.	Dowel Pin	222.	Valve Lifter Pin
143.	Hydraulic Relay Gasket	223.	Unloader Power Element Assembly
144.	Oil Pump Package	224.	Unloader Cylinder Bracket
145.	Oil Pump Cover	225.	Unloader Cylinder Gasket (Bottom)
146.	Capscrew	226.	Unloader Cylinder
147.	Oil Flow Cap	227.	Unloader Piston
148.	Oil Flow Cap Gasket	228.	Unloader Piston Rod
149.	External Valve Assembly	229.	Unloader Spring
150.	Valve Body with Bellows	230.	Unloader Spring
151.	Spring	231.	Unloader Spring
152.	Bearing Head Gasket	232.	Unloader Spring
153.	Seal Plug	233.	Unloader Cylinder Gasket (Top)
154.	Bearing Head and Oil Pump Assembly	234.	Unloader Fork
155.	Socket Head Pipe Plug	235.	Cylinder Cover Plate Assembly
156.	Equalizer Valve Spring	236.	Lockwasher
157.	Equalizer Valve Seat	237.	Capscrew
158.	Oil Pump Package	238.	Cotter Pin
159.	Pump Cover Gasket	239.	Plate Washer
160.	Socket Head Capscrew	240.	Clevis Pin
161.	Capscrew Gasket	241.	Unloader Bracket Gasket
162.	Surge Cover	242.	Socket Head Capacity
163.	Surge Cover Gasket	243.	Lockwasher 5/16"
164.	Capscrew	244.	Hand Hole Cover and Sight Glass Assembly
		254.	Hand Hole Cover for Interconnection



COMPRESSOR/CONDENSING UNITS

5H
FREON

ITEM NO.	PART NAME	LDC	REPLACEMENT PART NUMBER	UNIT USAGE						
				40	46	60	66	80	86	120

COMPRESSOR BODY GROUP

NI	Gasket Set		AC 5H40-502 AC 5H60-502 AC 5H80-502 AC 5H120-502	1	1		1	1												
56	Crankcase Assembly		NA 5H40-124 NA 5H60-124 NA 5H80-129 NA 5H86-129 AC	1	1		1	1												
57	Each Includes: Main Bearing	(1) 5H40-1012	AC																	
58	Groove Pin (Bearing Washer)	(1) AX35HR-120-012	PT																	
59	Crankcase Heater Casing 1 Required on 5H40-66 2 Required on 5H80-86 (Check Depth of Heater Casing to Select Proper Replacement):																			
	3-1/2 Deep	5F40-3742	AC																	
	4-3/8 Deep	5H40-3992	NS																	
	7-3/8 or 8-5/16 Deep	5F20-3742	AC																	
60	Dowel Pin (Valve Place) 1 per Cylinder	AX11AR-197-020	PT																	
NI	Adapter (Oil Filter or Plug)	(1) 5F20-1311 (1) 5H40-1141	AC AC																	
61	Heater Casing and Adapter Gasket	(2) AU51YA-011-012 (3) AU51YA-011-012	PT PT																	
NI	Tube Ferrule 3/16 on 5H40-46	(6) 5H40-1531	AC																	
	on 5H60-86	(8) 5H40-1531	AC																	
NI	Tube Ferrule 1/4 on 5H80-86	(2) 5H40-1541	AC																	
	Tube Ferrule 3/8 on 5H40-86	(2) 5H81-1551	AC																	
NI	Hollow Setscrew (80-86)	(1) AF20AA-313-005	PT																	
NI	Setscrew (80-86)	(1) BE72AR-320	NS																	
	Oil Supply Tubing 5H40-46 Includes:																			
NI	Oil Suction Tube	(1) 5H40-772	AC																	
NI	Oil Tube to Cyl. 1L	(1) 5H40-1953	AC																	
NI	Oil Tube to Cyl. 2R	(1) 5H40-1943	AC																	
NI	Oil Tube to Cyl. 1R	(1) 5H40-1163	AC																	
NI	Seal End Brg. Supply	(1) 5H40-1342	AC																	
NI	Oil Supply Tubing 5H60-66 Includes:																			
NI	Oil Suction Tube	(1) 5H40-772	AC																	
NI	Oil Tube to Cyl. 1L	(1) 5H60-1133	AC																	
NI	Oil Tube to Cyl. 2L	(1) 5H60-1143	AC																	
NI	Oil Tube to Cyl. 2R	(1) 5H60-1153	AC																	
NI	Oil Tube to Cyl. 1R	(1) 5H60-1163	AC																	
NI	Seal End Brg. Supply	(1) 5H60-1342	AC																	

NOTE: Cylinder identification is done by looking at Compressor from Pump End.
Ex: On 5H120 3L is 3rd Cylinder from Pump End on Left Hand Cylinder Bank.



COMPRESSOR/CONDENSING UNITS

5H
FREON

ITEM NO.	PART NAME	LDC	REPLACEMENT PART NUMBER	UNIT USAGE							
				5H							
				40	46	60	66	80	86	120	126

COMPRESSOR BODY GROUP (CONT'D.)

NI	Oil Supply Tubing 5H80-86 Includes:																		
NI	Oil Suction Tube (1) 5H40-772	AC																	
NI	Oil Tube to Cyl. 1R (1) 5H80-1823	AC																	
NI	Oil Tube to Cyl. 2R (1) 5H80-1833	AC																	
NI	Oil Tube to Cyl. 1L and 2L (1) 5H80-343	AC																	
NI	Oil Tube to Cyl. 3L and 4L (1) 5H80-853	AC																	
NI	Seal End Brg. Supply 5H80 Only (1) 5H81-1342	AC																	
NI	Pump End to Ctr. Brg. 5H86 Only (1) 5H86-102	AC																	
NI	Center Brg. to Seal End 5H86 Only (1) 5H86-112	AC																	
NI	Center Brg. Elbow (1) DD10CA-103	AC																	
56	Crankcase Assembly Includes:	NA	5H120-129																1
		NA	5H126-129																1
57	Main Bearing, Seal End (1) 5H40-1012	AC																	
58	Roll Pin (Brg. Washer) (1) AX14CA-222	AC																	
60	Dowel Pin (Valve Plate) (12) AX11AR-197-020	PT																	
59	Crankcase Heater Casing (Check Depth of Heater Casing to Select Proper Replacement)																		
	3-1/2 Deep (2) 5F40-3742	AC																	
	4-3/8 Deep (2) 5H40-3992	AC																	
	7-3/8 or 8-5/16 Deep (2) 5F20-3742	AC																	
61	Magnetic Plug (1) CA99AA-101	AC																	
62	Seal Plug (1) 5H120-2181	NS																	
63	Gasket (2) AU51YA-013-020	PT																	
NI	Hollow Setscrew (1) AF20AA-313-005	PT																	
NI	Setscrew (1) BE72AR-320	NS																	
NI	Oil By-Pass Plug (2) 5H40-1141	AC																	
NI	Plug & Htr. Gasket (4) AU51YA-011-012	PT																	
NI	Tube Ferrule 1/4 (8) 5H120-4502	AC																	
NI	5/16 (4) 5H120-4512	AC																	
NI	5/8 (1) 5H120-4522	AC																	
NI	3/8 (1) 5H81-1551	AC																	
NI	Oil Tube to Cyl. 3L & 4L (1) 5H120-524	AC																	
	3C & 4C (1) 5H120-813	AC																	
NI	3R & 4R (1) 5H120-823	AC																	
NI	3L & 4L (1) 5H120-2173	AC																	
NI	3C & 4C (1) 5H120-2133	AC																	
NI	3R & 4R (1) 5H120-2113	AC																	
NI	5H120 Only 1L & 1R (1) 5H120-514	AC																	
NI	5H120 Only 3R & 4R (1) 5H120-823	AC																	
NI	5H126 Only 1L & 1R (1) 5H126-134	AC																	
NI	5H126 Only 3R & 4R (1) 5H126-113	AC																	
NI	Pump End to Center Tee (1) 5H120-4602	AC																	
NI	Center Tee to Seal End (1) 5H120-4612	AC																	
NI	Center Tee to Ctr. Brg. (1) 5H120-972	AC																	
NI	Equalizer Line (Seal End (Seal End) (1) 5H120-833	AC																	
NI	Ermeto Union 5/16 (3) DC06SA-076	AC																	
NI	Ermeto Union Tee 5/8 (1) DC18SA-301	AC																	
NI	Ermeto Reducer 5/8 x 1/2 (1) DC04SA-302	AC																	
NI	Elbow 3/8 FL x 1/4 MPT (2) DD10CA-103	AC																	



COMPRESSOR/CONDENSING UNITS

5H
FREON

ITEM NO.	PART NAME	LDC	REPLACEMENT PART NUMBER	UNIT USAGE							
				5H							
				40	46	60	66	80	86	120	126
COMPRESSOR BODY (CONT'D.)											
64	Crankcase Heater Element PSN F7 6/77 115V, 200W, 6" Long 230V, 200W, 6" Long (Used in Well 5F20-3742) 115V, 100W, 3-1/8" Long 230V, 100W, 3-1/8" Long (Used in Well 5F40-3742) and 5H40-3992) SSN F7 6/77 115V, 200W, 8-1/4" Long 230V, 200W, 8-1/4" Long (Used in Well 5F20-3742)	AC AC AC AC AC AC	HT31AR-200 HT31AR-230 HT31AR-100 HT31AR-130 HT31AZ-131 HT31AZ-241	1 1 1 1 1 1	1 1 1 1 1 1	1 1 1 1 1 1	2 2 2 2 2 2	2 2 2 2 2 2	2 2 2 2 2 2	2 2 2 2 2 2	
NI	Heater Coupling (1" Conduit)	AC	HW25FA-005	1	1	1	1	2	2	2	2
65	Crankcase Heater Relay 115V, 60 Hz 208/230V, 50/60 Hz	AC AC	HN61AJ-101 HN61AJ-108	1 1	1 1	1 1	1 1	1 1	1 1	1 1	1 1
NI	Oil Return Check Valve Includes:	AC	5H40-932	2	2	2	2	2	2		
66	Check Valve	NSS									
67	Check Valve Gasket (1) 5H40-1171-012	PT									
68	Machine Screw w/Washer #12-24 1/2" Long	PT	AC73AA-146-020	4	4	4	4	4	4		
NI	Cover, Gas Equalizer Connection	AC	5H120-4432							1	1
NI	Gasket, Gas Equalizer Connection	PT	7K4-4522-012							1	1
69	Center Bearing, Half	AC	5H80-1242					2	1	1	1
70	Center Bearing Top Half	AC	5H120-1242						1	1	1
71	Center Bearing Housing	AC AC	5H80-204 5H120-204					1	1	1	1
72	Cylinder Head	AC	5H60-1004	2	2	3	3	4	4	4	4
73	Cylinder Head, Center Bank	AC	5H120-1004							2	2
74	Cylinder Head Gasket	PT	5H40-1093-010	2	2	3	3	4	4	6	6
NI	Water Cooled Cylinder Head Pkg. (Obtain from Finished Goods)	NA NA NA NA	5H40-507 5H60-507 5H80-507 5H120-507	1	1	1	1	1	1	1	1



COMPRESSOR/CONDENSING UNITS

5H
FREON

ITEM NO.	PART NAME	LDC	REPLACEMENT PART NUMBER	UNIT USAGE							
				5H							
				40	46	60	66	80	86	120	126

COMPRESSOR BODY (CONT'D.)

ITEM NO.	PART NAME	LDC	REPLACEMENT PART NUMBER	INCLUDED ON			
				5H40 507	5H60 507	5H80 507	5H120 507
	Each Includes:						
NI	Cylinder Head	AC	5H41-1019	2	3	4	6
NI	Cylinder Head, Center	AC	5H121-1019				2
NI	Cylinder Head Gasket	PT	5H40-1093-010	2	3	4	6
NI	Cylinder Head Cover	AC	5H61-1039	2	3	4	4
NI	Cyl. Head Cover Center Left S.E.	AC	5H121-1434				1
NI	Cyl. Head Cover Center Right S.E.	AC	5H121-1424				1
NI	Cyl. Head Cover Center Left P.E.	AC	5H121-1044				1
NI	Cyl. Head Cover Center Right P.E.	AC	5H121-1054				1
NI	Cylinder Head Cover Gasket	AC	5H41-1703	2	3	4	4
NI	Cylinder Head Cover Gasket, Center	AC	5H121-1703				4
NI	Hex Head Capscrew, 3/8-16 x 1-1/4 Lg.	PT	AA06BR-232-012	32	48	64	72
NI	Hex Head Capscrew 7/16-14 x 4-1/4 Lg.	PT	AA06BR-274-010	32	48	64	64
	Hex Head Capscrew 7/16-14 x 5-1/8 Lg.	AC	AA06BR-977				32
	Hex Head Capscrew 3/8-16 x 1-1/2 Lg.	PT	AA06BR-233-012				32
NI	Half Union Elbow 5/8 FL x 1/2 MPT	AC	DD10CA-302	1	4	4	12
NI	Half Union Coupling	AC	DD07DA-302	1		2	
NI	Half Union Elbow 1/2 FL x 3/8 MPT	AC	DD10CA-203				2
NI	Discharge Manifold Gasket	AC	5H80-4472				2
NI	Discharge Valve Gasket	PT	5H80-1632-012				1
NI	Relief Valve Gasket	PT	7K4-4522-012				3
NI	Flange Spacer	AC	5H120-5952				1
NI	Hex Head Capscrew 1/2-13 x 2" Lg.	AC	AA06BR-295				2
75	Suction Strainer Assembly	✓ AC	5H40-323	1	1		
		✓ AC	5H60-132		2	2	
		✓ AC	5H80-323			1	1
		✓ AC	5H120-794				2
76	Suction Strainer Gasket	AC	5H40-1361	1	1		
		AC	5H60-1831		2	2	
NI	Suction Filter Package	✓ AC	5H40-A382	1	1		
		✓ AC	5H60-A382		1	1	
		✓ AC	5H80-A382			1	1
		✓ AC	5H120-A382				1
NI	Includes: Felt Filter on 5H40 (1) 5H40-4032 5H60 (2) 5H60-4032 5H80 (1) 5H80-4032 5H120 (2) 5H120-4552	✓ AC ✓ AC ✓ AC ✓ AC					
77	Cylinder Sleeve (With Holes) (Use in place of Sleeves w/o Unloader Pin Holes)	✓ AC	5H40-1003	4	6	8	12
		✓ AC	5H46-1003	4	6	8	12
78	Cylinder Sleeve Snap Ring	✓ AC	5H40-2221	3	3	4	4
79	Oil Screen Package	✓ AC	5H40-237	1	1	1	1
NI	Includes: Oil Screen Gasket (2) 5H40-1371	✓ AC					
80	Oil Screen and Suction Tube Assembly	✓ AC	5H120-252				1
81	Oil Suction Tube Gasket	✓ AC	5H120-3451				1



COMPRESSOR/CONDENSING UNITS

5H
FREON

ITEM NO.	PART NAME	LDC	REPLACEMENT PART NUMBER	UNIT USAGE							
				5H							
				40	46	60	66	80	86	120	126
COMPRESSOR BODY GROUP (CONT'D.)											
NI	Suction and Discharge Manifold (For 4 Bolt Valve)	AC	5H60-1714				2	2			
NI	Manifold Gasket	PT	5H60-1681-012				4	4			
82	Suction and Discharge Manifold Cover	AC	5H40-1052	1	1				1	1	
83	Manifold Cover Gasket	AC	5H40-1032	1	1				1	1	
NI	Suction Manifold Cover Plate	AC	5H80-1892						1	1	
NI	Suction Manifold and Disch. Valve Gasket	PT	5H60-1632-012						2	2	
84	Suction Manifold (For 4 Bolt Valve) (8 Bolt Valve Manifold N/A)	AC	5H120-1299								1 1
85	Suction Manifold Cover	NS	5H120-4452								2 2
86	Suction Manifold and Cover Gasket	AC	5H120-4462								4 4
87	Discharge Manifold (For 4 Bolt Valve) (8 Bolt Valve Manifold N/A)	AC	5H120-1279								1 1
88	Discharge Manifold Gasket	AC	5H120-4472								2 2
NI	Suction and Discharge Manifold Mounting Bolts (1/2-13 x 4 Lg.)	AC	AA06BR-303				16	16			
89	Suction Manifold Mounting Bolts (5/8-11 x 6-1/2 Lg.)	NS	AH06BR-340								8 8
9	Capscrew Gasket 1/2 5/8 (Not Used on Current Production)	PT PT	AU51YA-009-012 AU51YA-011-012						16	16	8 8
NI	Manifold Cover Plate (Top of Crankcase Between Valves)	AC	7J1-6002						1	1	
NI	Cover Plate Gasket	PT	6D40-1061-012						1	1	
91	Internal Relief Valve - 300 Psi	AC	EB51FH-270	1	1	1	1	1	1	1	
92	Discharge Pressure Relief Valve Assy. Includes: Valve (1) EB51FN-870 Gasket (2) EP29YC-360	AC AC AC	5H120-337								1 1
NI	Relief Valve Line Gaskets	PT	7K4-4522-012								2 2
@Parts for Adjustable Oil By-Pass Valve											
93	Oil By-Pass Plug	AC	5H40-1141	1	1	1			1		
94	Oil By-Pass Plug Gasket	PT	AU51YA-011-012	1	1	1			1		
95	Oil By-Pass Lockscrew 5/8-18 x 5/16 Lg.	PT	AF20AA-313-005	1	1	1			1		
96	Oil By-Pass Adjusting Screw	AC	5H40-1121	1	1	1			1		
97	Oil By-Pass Spring	AC	7K3-4182	1	1	1			1		
98	Oil By-Pass Valve	AC	5H40-1111	1	1	1			1		



COMPRESSOR/CONDENSING UNITS

5H
FREON

ITEM NO.	PART NAME	LDC	REPLACEMENT PART NUMBER	UNIT USAGE							
				5H							
				40	46	60	66	80	86	120	126
COMPRESSOR BODY GROUP (CONT'D.)											
99	∅ Non-Adjustable Oil Pressure Regulator Pkg. Includes:	AC	√ 5H40-962	1	1	1	1	1	1		
100	Gasket (1) AU51YA-011-012	PT									
101	Regulator Valve (1) 5H40-782	NSS									
103	Regulator Valve Cap (1) 5H40-3982	AC									
∅ NOTE: The Non-Adjustable Oil Pressure Regulator is a replacement for the Adjustable Oil By-Pass Valve Parts.											
101	Oil Pressure Regulator Valve	AC	√ 5H120-782							1	1
102	Regulator Valve Gasket	PT	AU51YA-013-012							1	1
103	Regulator Valve Cap	AC	• 5H120-3381							1	1
104	Cylinder Head Bolt (7/16-14 x 3-1/2 Lg.)	PT	• AA06BR-271-020	32	32	48	48	64	64	96	96
105	Capscrew Gasket 7/16 (Not Used on Current Production)	PT	• AU51YA-008-012	38	38	48	48	64	64	182	182
106	Angle Valve (to Oil Filter)	AC	• EP23LC-090	2	2	2	2	2	2		

SEAL END GROUP

107	Replacement Seal Package Rotary Sleeve Type Includes:	AC	√ 5H40-276	1	1	1	1	1	1		
108	Cover Plate Gasket (1) 5H40-3692	AC									
109	#Carbon Washer (1) SHD-1258-A	NSS									
110	Cover Plate w/o Integral Seat Seal (1) 5H40-2433	AC									
111	Replacement Seal Package Rotary Sleeve Type Includes:	AC	√ 5H120-732							1	1
112	Cover Plate Gasket (1) 5H40-3692	AC									
109	#Carbon Washer (1) SHD-1258-A	NSS									
110	Cover Plate w/o Integral Seat Seal (1) 5H40-2433	AC									
# NOTE: Replacement only for washers damaged in shipping or installation. Do not replace on seals that have been in operation.											
The Rotary Sleeve type seal can be used as a replacement for either the early stationary or rotary bellows type.											
114	Seal Cover Plate Capscrew	PT	√ AA06BR-262-012	6	6	6	6	6	6	6	6
NI	Shaft Seal Cover Plate (For Early Rotary Bellows Type Seal)	NA	√ 5H40-3882	1		1		1			
NI	Cover Plate Gasket (For Early Rotary Bellows Type Seal)	AC	√ 5H40-1181	1		1		1			



COMPRESSOR/CONDENSING UNITS

5H
FREON

ITEM NO.	PART NAME	LDC	REPLACEMENT PART NUMBER	UNIT USAGE							
				5H							
				40	46	60	66	80	86	120	126
PUMP END GROUP											
115	Bearing Head and Oil Pump Assembly (Drilled for Oil Cooler) Includes:	AC	✓ 5H40-677	1	1	1	1	1	1		
116	Main Bearing (1) 5H40-1022 ^N	AC									
117	Magnetic Plug (1) CA99AA-101	AC									
118	Plug, Gasket ✓(1) AU51YA-011-012	PT									
NI	Capscrew 1/4-28 x 3/4 (Oil Pump Cover) (4) AB06BR-168-012	PT									
NI	Groove Pin (Brg. Washer) (1) AX35HR-120-012	PT									
NI	Sleeve (w/Oil Cooler) (1) 5H40-7252	AC									
119	Oil Pump Package (Matched Parts) (1)* 5H40-A372	AC									
	Includes:										
	Cover, Idler, Rotor and Bushing	NSS									
120	Pump Cover Gasket (1) 5F40-1211-012	PT									
121	Bearing Head Gasket (1) 5H40-1113-012	PT									
122	Pump End Gasket (1) 5H40-1423	AC									
123	Pump End Cover and Control Valve Assembly Includes:	AC	• 5H40-A564	1	1	1	1	1	1		
122	Pump End Cover Gasket (1) 5H40-1423	AC									
NI	Hydraulic Relay (Aux. Control Valve) (1) 5F40-767	AC									
NI	Oil By-Pass lug (2) 5H40-1141	AC									
NI	Control Oil Stariner (1) 5H40-1971	AC									
NI	Socket Head Capscrew 5/16-24 x 1 (2) AB44AA-704	AC									
NI	Hollow Lock Screw (1) AF20AA-313-005	PT									
NI	Capscrew Gasket (2) AU51YA-004-012	PT									
NI	Capscrew Gasket (2) AU51YA-011-012	PT									
124	Control Valve Package (1) 5F40-721	AC									
	Includes:										
125	External Valve Assy. (1) 5F-88213	AC									
126	Bellows Assembly (1) 05HG660014	AC									
127	7 lb. Spring (R12,500) (1) 5F-88206	AC									
NI	11 lb. Spring (R22) (1) EB39CZ-001	AC									
128	Valve Gasket Inner (1) 5H40-2001-012	PT									
129	Valve Gasket Outer (1) 5H40-1411-012	PT									
130	Socket Head Capscrew 1/2"-13 x 3	PT	• AA44AA-299-010	12	12	12	12	12	12	12	12
131	Capscrew Gasket 1/2"	PT	• AU51YA-009-012	12	12	12	12	12	12	12	12
132	Bearing Head and Oil Pump Assembly Starting Serial #0447119 Includes:	AC	• 5H120-837							1	1
NI	Sleeve (For Oil Cooler Application) (1) 5H40-7252	AC									
133	Main Bearing ×(1) 6L80-2172	AC									
134	Groove Pin (1) AX35HR-120-012	PT									
135	Adapter Plug (1) 6G40-1451	AC									
NI	Plug Gasket (1) AU51YA-011-012	PT									
NI	Socket Head Pipe Plug (5) CA64AA-001	AC									
136	Control Oil Strainer (1) 5H120-3301	AC									
NI	Cover, Surge Chamber (1) 6L45-1041	NS									
NI	Gasket, Chamber Cover (1) 5H120-3341-012	PT									
NI	Capscrew 3/8"-16 x 4" (1) _____	NA									
NI	Capscrew Gasket (1) AU51YA-005-012	PT									
137	Oil Filter By-Pass Spring (1) 5H120-1683	AC									



COMPRESSOR/CONDENSING UNITS

5H
FREON

ITEM NO.	PART NAME	LDC	REPLACEMENT PART NUMBER	UNIT USAGE						
				5H						
				40	46	60	66	80	86	120

PUMP END GROUP (CONT'D.)

132	Bearing Head and Oil Pump Assembly (Cont'd.) Includes:																		
138	By-Pass Retaining Ring (1) -AU47AR-087	NA																	
139	Valve Disc: By-Pass and Equalizer (2) 5H120-3411	AC																	
NI	Equalizer Valve Spring (1) 5H120-1593	AC																	
NI	Equalizer Valve Seat (1) 5H120-3401	AC																	
140	Angle Valve (1) EP23QA-090	AC																	
141	Hydraulic Relay (1) V6L45-123	AC																	
	(Auxiliary Control Valve Assembly) Includes:																		
NI	Cover Gasket (1) 5H120-3361-012	PT																	
NI	Ball 3/16" O.D. (2) KT37ZZ-013	AC																	
142	Dowel Pin 1/8 x 1/2 Lg. (2) AX11AR-062-010	PT																	
143	Hydraulic Relay Gasket (1) 5H120-3351-012	PT																	
	Socket Head Screw (2) AA44AA-206	AC																	
144	Oil Pump Package (For Current 5 H120-837 Pkg.) (Matched Parts)	AC																	
	Includes:																		
NI	Oil Pump Cover Gasket (1) 5H120-3891	AC																	
144	Oil Pump Package (For Former 5H120-747 Pkg.) (1) V06LA660008	AC																	
	Includes:																		
NI	Idler, Bushing and Rotor Pump Cover O-Ring (1) KK71GY-033	AC																	
145	Oil Pump Cover (For 5H120-837) (1) 5H120-2923	NS																	
	(For 5H120-747) (1) 5H120-6422	AC																	
146	Capscrew 5/16-18 x 1 (6) AA06BR-200-012	PT																	
147	Oil Flow Cap (1) 6L45-1122	NA																	
148	Oil Flow Cap Gasket (1) 6L45-1132	AC																	
NI	Capscrew Gasket (10) AU51YA-003-012	PT																	
	(Oil Flow Cap and Oil Pump Cover)																		
NI	Capacity Control Valve (1) 5F40-721	AC																	
	Includes:																		
149	External Valve Assy. (1) 5F-88213	AC																	
150	Bellows (1) 05HG660014	AC																	
151	7 lb. Spring (RR,R500) (1) 5F-88206	AC																	
151	11 lb. Spring (R22) (1) EB39CZ-001	AC																	
	Valve Gasket (Inner) (1) 5H40-2001-012	PT																	
	(Outer) (1) 5H40-1411-012	PT																	
NI	Socket Head Screw (2) AA44AA-206	AC																	
NI	Capscrew Gasket (2) AU51YA-004-012	PT																	
152	Bearing Head Gasket (1) 5H120-1653	AC																	
153	Seal Package (1) 5H120-3821	NS																	
NI	Gasket (1) AU51YA-003-012	PT																	



COMPRESSOR/CONDENSING UNITS

5H
FREON

ITEM NO.	PART NAME	LDC	REPLACEMENT PART NUMBER	UNIT USAGE						
				5H						
				40	46	60	66	80	86	120
PUMP END GROUP (CONT'D.)										
154	Bearing Head and Oil Pump Assembly Prior to Serial #0447119 (with external Capacity Control Valve) Includes:	NA								
133	Main Bearing	AC ✓	-5-H--40--1022--						1	1
155	Socket Hd. Pipe Plug 1/8"	AC ✓	--CA--64AA-001--						4	4
137	Oil Filter By-Pass Spring	AC ✓	-5-H-120--1683--						1	1
138	By-Pass Retaining Ring	AC ✓	--AU--47AA-087--						1	1
139	Valve Disc, By-Pass and Equalizer Valve	AC ✓	-5-H-120--3411--						2	2
156	Equalizer Valve Spring	AC ✓	-5-H-120--1593--						1	1
157	Equalizer Valve Seat	AC ✓	-5-H-120--3401--						1	1
158	Oil Pump Pkg. (Matched Parts) Includes: Cover, Idler, Rotor and Bushing	AC ✓	06LA-660---008--						1	1
159	Pump Cover Gasket	AC ✓	-5-H-120--3431--						1	1
152	Bearing Head Gasket	AC ✓	-5-H-120--1653--						1	1
136	Control, Oil Strainer	AC ✓	-5-H-120--3301--						1	1
146	Capscrew 5/16-18 x 1	NA ✓	--AA--44BR-200--						6	6
160	Socket Head Capscrew	AC ✓	--AA--44AA-206--						6	6
161	Capscrew Gasket	MP ✓	--AU--51YA-004--						10	10
162	Surge Cover	NA ✓	-5-H-120--3331--						1	1
163	Surge Cover Gasket	MP ✓	-5-H-120--3341--						1	1
164	Capscrew 3/8-16 x 4	NA ✓	--AA--44BR-200--						1	1
165	Capscrew Gasket	MP ✓	--AU--51YA-005--						1	1
166	Oil By-Pass Plug	AC ✓	-5-H--40--1141--						1	1
143	Hydraulic Relay Gasket	MP ✓	-5-H-120--3351--						1	1
141	Hydraulic Relay (Auxiliary Control Valve) Includes:	AC ✓	-6-L--45---123--						1	1
NI	Cover Gasket	MP ✓	-5-H-120--3361--						1	1
NI	Ball 3/16" O.D.	AC ✓	--KT--37ZZ-013--						2	2
167	Capacity Cont. Valve Pkg Includes:	NA ✓	-5-H-121---417--						1	1
168	Control Valve Gasket	AC ✓	-5-H-120--4642--						1	1
NI	Range Spring R12	AC ✓	--EM--99AS-100--						1	1
NI	Range Spring R22	AC ✓	--EM--99AS-120--						1	1
169	Capscrew 1/2-13 x 4-1/4 Lg.	AC ✓	--AA--46BR-304--						12	12
170	Capscrew Gasket 1/2"	MP ✓	--AU--51YA-009--						12	12
171	Double Branch Angle Valve++	AC ✓	--P--32TA-150--	1	1	1	1	1	1	1
172	Angle Valve 1/4 x 1/4++	AC ✓	--EP--33LC-090--	1	1	1	1	1	1	1
173	Oil Pressure Gauge (0-200#)++ ++ NOTE: PSN D707060 parts are standard. SSN D707060 parts are only included if Oil Filter Pkg. was installed. Shipping, Storage Valves on current units should be removed and connections plugged.	AC ✓	--KM--31BC-200--	2	2	2	2	2	2	2
NI	Pipe Plug 1/4"	AC ✓	--CA--63AA-051--	2	2	2	2	2	2	2



COMPRESSOR/CONDENSING UNITS

5H
FREON

ITEM NO.	PART NAME	LDC	REPLACEMENT PART NUMBER	UNIT USAGE							
				5H							
				40	46	60	66	80	86	120	126

PUMP END GROUP (CONT'D.)

2PZ

174	Oil Filter Cartridge Package Includes:	AC	5H120-351								1	1
175	Oil Filter Cover Gskt (1) 5H120-4492 ✓ Oil Filter Cartridge (1) KH09TC-120 ✓	AC NSS.										
176	Oil Filter Spring	AC	° 5H120-1643								1	1
177	Oil Filter Housing	AC	° 5H120-1334								1	1
178	Oil Filter Housing Gasket	AC	° 5H120-4482								1	1
179	Socket Head Capscrew 1/2-16 x 1/4	PT	AA44AA-292-010								4	4
180	Capscrew Gasket 1/2	PT	° AU51YA-009-012								4	4
181	Oil Filter Cover	AC	° 5H80-1892								1	1
182	Oil Filter Spring Retainer	AC	° 5H120-3441								1	1

On Units produced before July 1973, a complete Capacity Control Valve Pkg (Part #5F40-721) is required. This package contains Inner and Outer Seal Gaskets (5H40-2001 and 5H40-1411). On Units manufactured after July 1973, the Bellows Assembly can be replaced by itself, if desired. The Part Number for the Bellows Package is 05HG660014. When using this Bellows Assembly, you must also use (1) 5H40-1411 (Outer Seal Gasket) and (1) 5H40-2001 (Inner Seal Gasket). These Gaskets aren't included with the Bellows Assembly and both are sold in packages of 12.

CRANKSHAFT AND PISTON GROUP

183	Crankshaft Assembly	AC	✓ 5H40-562	1								
		AC	✓ 5H46-114		1							
		AC	✓ 5H60-114			1						
		AC	✓ 5H66-562				1					
		AC	✓ 5H80-562					1				
		AC	✓ 5H86-562						1			
		AC	✓ 5H120-562								1	
		AC	✓ 5H126-562									1
184	Flywheel Drive Key	AC	° 5H40-2851	1	1	1	1	1	1	1	1	1
185	Flywheel Washer	AC	✓ 5H40-1401	1	1	1	1	1	1	1	1	1
186	Flywheel Lockwasher	PT	° AU29AR-331-012	1	1	1	1	1	1	1	1	1
187	Flywheel Capscrew 5/8-18 x 1-1/2	PT	✓ AB06BR-323-010	1	1	1	1	1	1	1	1	1
188	Connecting Rod Package (Steel Rod) SSN F701597 (See Note #2 on Pg. 59)	AC	✓ 5H40-103	4		6		8		12		
		AC	✓ 5H40-103		4		6		8			12
	Includes:											
189	Connecting Rod Bolt ✓ (2) 5H40-1041	AC										
190	Connecting Rod Nut ° (2) AT61AA-272-010	PT										
	Connecting Rod ✓ (1) 5H40-1293	NSS										
NI	Piston Pin Bushing ° (1) 5H40-1031	NSS										
NI	Connecting Rod Bearing Package SSN F701597	AC	✓ 5H40-451	2		3		4		6		
	Includes:	AC	✓ 5H40-451		2		3		4			6
191	Connecting Rod Bearing Half ✓ (4) 5H40-1002 (Conn. Rod Brgs. not req'd on alum. rods.)	NSS										



COMPRESSOR/CONDENSING UNITS

5H
FREON

ITEM NO.	PART NAME	LDC	REPLACEMENT PART NUMBER	UNIT USAGE							
				5H							
				40	46	60	66	80	86	120	126
CRANKSHAFT AND PISTON GROUP (CONT'D.)											
188	Connecting Rod Package (Alum. Rod) PSN F701597 (See Note #2) Includes:	AC	✓ 5H46-953		4		6		8		12
189	Connecting Rod Bolt	NSS	• (2) 5H46-1041								
NI	Lock Washer	AC	• (2) 5H460-2041								
NI	Plain Washer	PT	• (2) AUC2AA-242-020								
	Connecting Rod	NSS	• (1) 5H46-1293								
	Dowel Pin	PT	• (2) 7J1-6032-012								
192	Seal End Bearing Washer	AC	✓ 5H40-1062	1	1	1	1	1	1		
193	Seal End Thrust Washer	AC	✓ 5H40-1072	1	1	1	1	1	1		
		AC	✓ 5H120-1072							1	1
194	Pump End Bearing Washer	AC	✓ 5H40-1082	1	1	1	1	1	1	1	1
195	Piston and Pin Assy. (Unassembled) Includes:	AC	✓ 5H40-482	4		6		8		12	
	Piston	AC	✓ 5H46-482		4		6		8		12
196	Piston Pin	NSS	(1)								
197	Piston Pin	AC	(1) 5H40-1051 ✓								
198	Piston Pin Lock Ring	PT	(1) 5H40-3531-012 ✓								
	Piston Rings (See Note #1)										
199	- Oil	NSS	✓ 5H40-1091	8	4	12	6	16	8	24	12
200	- Compression	NSS	✓ 5H40-1071	8		12		16		24	
	- Compression	NSS	✓ 5H46-1071		8	12		16			24
<p>NOTE: 1: Piston Rings are available in packages only. For 5H40, 60, 80 and 120 Compressors, order 5H40-481 which includes: (8) 5H40-1091 Oil Rings (8) 5H40-1071 Compression Rings For 5H46, 66, 86 and 126 Compressors, order 5H46-481 which includes: (4) 5H40-1091 Oil Rings (8) 5H46-1071 Compression Rings</p> <p>2: SSN F701597 Long Stroke Compressors (5H46, 66, 86 and 126) are built using Steel Rods as found in 5H40-103 Conn. Rod Pkg. When replacing individual rods in L.S. Compressors PSN F701597 Aluminum Conn. Rod Pkg. 5H46-953 should be used. Caution should be used that a mixture of Aluminum and Steel Rods are not used in the same compressor.</p>											
201	Oil Recovery Impeller	AC	✓ 5H120-1354							1	1
202	Headed Dowel Pin	AC	✓ 5H120-2191							1	1



COMPRESSOR/CONDENSING UNITS

5H
FREON

ITEM NO.	PART NAME	LDC	REPLACEMENT PART NUMBER	UNIT USAGE							
				5H							
				40	46	60	66	80	86	120	126

UNDERSIZE CRANKSHAFT AND BEARING GROUP

NI	.010" Undersize Crankshaft and Bearing Pkg.	NA	✓ 5H40-544	1							
		NA	✓ 5H60-544			1					
		NA	✓ 5H80-544					1			
		NA	✓ 5H120-544								1
	Each Includes:										
NI	Crankshaft (1) See Note #2	NSS									
NI	Connecting Rod Brg. Half See Note #1										
	on 5H40 (8) 5H40-3612 ✓	NSS									
	on 5H60 (12) 5H40-3612 ✓	NSS									
	on 5H80 (16) 5H40-3612 ✓	NSS									
	on 5H120 (24) 5H40-3612 ✓	NSS									
NI	Seal End Main Bearing (1) 5H40-3632 ✓	AC									
NI	Pump End Main Bearing (1) 5H40-3652 ✓	AC									
NI	Center Bearing										
	on 5H80 only (2) 5H80-3672 ✓	AC									
	on 5H120 only (1) 5H80-3672 ✓	AC									
NI	Center Brg. (5H120 Only) (1) 5H120-3672 ✓	AC									
NI	.020" Undersize Crankshaft and Bearing Pkg.	NA	5H40-554	1							
		NA	5H60-554			1					
		NA	5H80-554					1			
		NA	5H120-554								1
	Each Includes:										
NI	Crankshaft (1) See Note #3										
NI	Connecting Rod Brg. Half See Note #1										
	on 5H40 (8) 5H40-3622 ✓	NSS									
	on 5H60 (12) 5H40-3622 ✓	NSS									
	on 5H80 (16) 5H40-3622 ✓	NSS									
	on 5H120 (24) 5H40-3622 ✓	NSS									
NI	Seal End Main Bearing (1) 5H40-3642 ✓	AC									
NI	Pump End Main Bearing (1) 5H40-3662 ✓	AC									
NI	Center Brg. (5H80 Only) (2) 5H80-3682 ✓	AC									
NI	Center Bearing										
	(Top 5H120 Only) (1) 5H120-3682 ✓	AC									
NI	Center Bearing										
	(Bottom 5H120 Only) (1) 5H80-3682 ✓	AC									
	Bearings for .030" Undersize Crankshaft										
	Connecting Rod Bearing Half (See Notes 4&5)										
	on 5H40 (8) 5H40-1002-S3 ✓	NSS									
	on 5H60 (12) 5H40-1002-S3 ✓	NSS									
	on 5H80 (16) 5H40-1002-S3 ✓	NSS									
	on 5H120 (24) 5H40-1002-S3 ✓	NSS									
	Seal End Main Bearing (1) 5H40-1012-S3	AC									
	Pump End Main Bearing (1) 5H40-1022-S3	AC									
	Center Bearing										
	on 5H80 only (2) 5H80-1242-S3	AC									
	on 5H120 only ✓(1) 5H80-1242-S3	AC									
	✓(1) 5H120-1242-S3	AC									

- NOTES:**
- Parts (5H40-3612 and 5H40-3622, Connecting Rod Bearings are available in packages only. For .010" Undersize order 5H40-461 which includes: (4) 5H40-3612 Bearing Halves. For .020" Undersize order 5H40-471 which includes: (4) 5H40-3622 Bearing Halves.
 - .010" Undersize is identified by an "A" stamped on Crankshaft.
 - .020" Undersize is identified by a "B" stamped on Crankshaft.
 - .030" Undersize is identified by a "30" stamped on Crankshaft.
 - Part 5H40-1002-S3, Connecting Rod Bearings are available in package only.. Order 5H40860001 which includes: (4) 5H40-1002-S3 Bearing Halves



COMPRESSOR/CONDENSING UNITS

5H
FREON

ITEM NO.	PART NAME	LDC	REPLACEMENT PART NUMBER	UNIT USAGE							
				5H							
				40	46	60	66	80	86	120	126
VALVE PLATE GROUP											
203	Valve Plate Package	AC	✓ 5H40-120A	2		3		4		6	
		AC	✓ 5H46-120A		2		3		4		6
	<i>NOTE: To identify package, inspect Valve Plate. "ES" will be stamped on edge of Valve Plate used in 5H46-120A.</i>										
	Includes:										
204	Valve Plate (1)	NSS									
205	Valve Plate Gasket (1) 5H40-1083-030	PT									
74	Cylinder Head Gasket (1) 5H40-1093-010	PT									
205	Suction Valve (2) 5H40-1142	AC									
207	Suction Valve Spring (12) 5H40-1791-012	PT									
NI	Valve Clip (For Assembling Only) (4) 5F20-2061	AC									
208	Lockwasher (6) 5H40-1481-012	PT									
209	Screw 5/16-24 x 1-1/4 (Guide) (6) ABO6BR-202-012	PT									
210	Discharge Valve Guide (2) 5H40-A552	AC									
	Includes:										
211	Lockplate (1) 5H40-1201	AC									
212	Guide (1) 5H40-1553	AC									
213	Discharge Valve (1) 5H40-1132	AC									
214	Discharge Valve Spring (6) 5H40-7322-012	PT									
215	Screw 5/16-24 x 1-1/4 (Lockplate to Guide) (3) ABO6BR-202-012	PT									
216	Dowel Pin 3/16" Dia. (2) AX11AR-128-020	PT									
217	Dowel Pin 1/4" Dia. (1) AX11AR-162-020	PT									
	Inner Seat (1) 5H40-1191	AC									
218	Capscrew (7/16-14 x 1-1/4) Plate to Crankcase	PT	AAO6BR-262-012	4	4	6	6	8	8	12	12
219	Capscrew Gasket 7/16" (Not Used in Current Production)	PT	AU51YA-008-012	4	4	6	6	8	8	12	12

UNLOADER GROUP

220	Unloader Sleeve	AC	✓ 5H40-1752	3	3	4	4	6	6	8	8
221	Valve Lifter Spring	PT	✓ 5H40-2241-012	18	18	24	24	36	36	48	48
222	Valve Lifter Pin	AC	✓ 5H40-2231	18	18	24	24	36	36	48	48
223	Unloader Power Element Assembly	AC	✓ 5H40-163	3	3	4	4	6	6	8	8
	Includes:										
224	Unloader Cyl. Bracket (1) 5H40-1762V	AC									
225	Unloader Cylinder Gasket (Bottom) (1) 5H40-1711-012	PT									
226	Unloader Cylinder (1) 5H40-1772	AC									
227	Unloader Piston (1) 5H40-1782	AC									
228	Unloader Piston Rod (1) 5H40-1731	AC									
229	Unloader Spring Retaining Washer (1) 5H40-1811	AC									
230	Unloader Spring (Inner) 3-19/32" Lg. (1) 5H40-1822	AC									
231	Unloader Spring (Middle) 3" Lg. (1) 5H40-2812	AC									
232	Unloader Spring (Outer) 2-3/32" Lg. (1) 5H40-1802	AC									
233	Unloader Cyl. Gskt (Top) (1) 5H40-1701-012	PT									



COMPRESSOR/CONDENSING UNITS

5H
FREON

ITEM NO.	PART NAME	LDC	REPLACEMENT PART NUMBER	UNIT USAGE							
				5H							
				40	46	60	66	80	86	120	126
UNLOADER GROUP (CONT'D.)											
223	Unloader Power Element Assy. (Cont'd.) Includes:										
234	Unloader Fork (1)-5-H--40--7312	AC									
235	Cyl. Cover Plate Assy. (1)-5-H--40--242	AC									
236	Lockwasher 5/16" (3)--AU--27AF-201	MP									
237	Capscrew 5/16-24 x 2-1/8" (3)--AB--06BF-574	MP									
238	Cotter Pin 1/16" x 3/8 (1)--AX--01AF-003	MP									
239	Plate Washer (1)-5-F--20--1301	MP									
240	Clevis Pin (1)-5-F--20--2571	AC									
241	Unloader Bracket Gasket	MP	5-H--40--1451--	3	3	4	4	6	6	8	8
242	Socket Head Capscrew 5/16-24 x 1-1/4	MP	AB--44AA-202--	6	6	8	8	12	12	16	16
243	Lockwasher 5/16	MP	AU--61ML-201--	6	6	8	8	12	12	16	16

HAND HOLE COVER GROUP

244	Hand Hole Cover and Sight Glass Assembly (1" Dia. Screw-In Type Sight Glass)	AC	5-H--40--102--	1	1	1	1	1	1		
		AC	5-H-120--102--							1	1
245	*ØSight Glass Package (1)-5-F--20--152 Includes:	AC									
246	Sight Glass (1)-5-F--20--781	NSS									
247	Sight Glass Gasket (1)-5-F--20--1631	MP									
	<i>NOTE: The 2-piece Sight Glass Package 5F20-152 replaces the 4-piece Screw-In type Sight Glass that has been used on some Hand Hole Covers.</i>										
	Old Style Hand Hole Cover used the following Bolt-On Type Sight Glass (1-1/2" Dia. Glass)										
248	Sight Glass (1)-5-H--40--1001	AC									
249	Inner Gasket (1)-5-H--40--1011	AC									
250	Sight Glass Clamping Gland (1)-5-H--40--1021	AC									
251	Outer Gasket (1)-5-H--40--1621	AC									
NI	Capscrew 5/16-18 x 5/8 (3)--AA--06BR-199	MP									
NI	Everlock Washer (3)--AA--27AF-201	MP									
252	Hand Hole Cover Gasket	MP		2	2	2	2	4	4	4	4
253	Hand Hole Cover Plain	NS	5-H--40--1304--	1	1	1	1	3	3	2	2
254	Hand Hole Cover for Interconnection (May be used on any size if required.) Includes:	NA	5-H--40--703							1	1
252	Hand Hole Cover Gasket (1) 5H40-1042-012	MP									
255	Capscrew 7/16-14 x 2-1/4	MP	AA--06ER-266--	26	26	26	26	54	54	54	54
256	Capscrew Gasket 7/16 (Not Used on Current Production)	MP	AU--51YA-008--	28	28	28	28	56	56	56	56
257	Oil Filter (External) (See Page 67.)		05HG-660--020--	1	1	1	1	1	1	1	1
NI	Half Union Elbow, Orifice	MP	DD--40CA-051	1	1	1	1	1	1	1	1



COMPRESSOR/CONDENSING UNITS

5H
FREON

ITEM NO.	PART NAME	LDC	REPLACEMENT PART NUMBER	UNIT USAGE							
				5H							
				40	46	60	66	80	86	120	126
HAND HOLE COVER GROUP (CONT'D.)											
258	Oil Filter Bracket	AC	° 5H40-2832	1	1	1	1	1	1	1	1
259	Control Bracket Stud	AC	√ 5H40-1781	4	4	4	4	4	4	2	2
NI	Elbow 1/4 x 1/4	PT	• DD10CA-052-005	1	1	1	1	1	1	1	1
260	Pressure Control Bracket (A-B) (Robertshaw)	NA	° 5F40-1372	1	1	1		1		1	
		NS	° 5F40-4922				1		1		1
		AC	* 5H40-7232	1	1	1	1	1	1	1	1
261	Pressurestat High Side Low Side High Side Low Side	AC	° HK02HA-012	1	1	1	1	1	1	1	1
		AC	° HK02HB-012	1	1	1	1	1	1	1	1
		AC	° * HK02UA-300	1	1	1	1	1	1	1	1
		AC	° * HK02UB-050	1	1	1	1	1	1	1	1
262	Pressurestat Tube Clip	AC	p 5F20-1501	2	2	2	2	2	2	2	
NI	Enclosure, Pressurestat (Robertshaw)	AC	° HK09UZ-012				1		1		1
	<p>* NOTE: The new Robertshaw bracket (5H40-7232) is required when replacing any old style Pressurestat (Dual or HK04UN-500 Type). When replacing a HK04UN-500 Pressurestat, both the high and low plus Bracket will have to be replaced.</p>										
NI	Oil Filter Package (Old Type)	NA	* 5H40-963	1	1	1	1	1	1		
	Includes:	AP	e 5H40-A274	1	1	1	1	1	1		
	Oil Filter (1), KH18BV-003	AC									
	Mounting Bracket (1), 5H40-2832	AC									
	Filter Inlet Tube Assy (Top)										
	Used on 5H60-66 (1), 5H60-166	NA									
	Filter Inlet Tube Assy (Top)										
	Used on 5H40, 46, 80, 86 (1), 5H40-166	AC									
	Filter Outlet Tube Assy (1), 5H40-176	AC									
	Angle Valve 1/4 FL x 1/4 MPT (1), EP23LC-090	AC									
	Half Union Elbow w/Orifice										
	1/4 FL x 1/4 MPT (1), DD40CA-051-005	PT									
	Double Branch Angle Valve (1), EP32TA-150	AC									
	Half Union Elbow										
	1/4 FL x 1/4 MPT (1), DD10CA-052-005	PT									
	Adapter (1), 5F20-1311	AC									
	Rd. Hd. Machine Screw										
	1/4-20 x 1-3/4 (1), AC15AA-174	NA									
	1/4-20 Hex Nut (1), AT39AA-171-020	PT									
	3/8 Lockwasher (2), AU11AA-241	NA									
	3/8-16 Hex Nut (2), AT39AA-241	AC									
	Control Bracket Studs (2), 5H40-1781	AC									
	7/16 Capscrew Gaskets (2), AU51YA-008-012	PT									
	5/8 Adapter Gasket (1), AU51YA-011-012	PT									
	Pressure Gauge (2), KM01BC-201	NA									
	Flare Gasket (1), DD24FA-051	NA									
	Washer 3/8 (2), AU01AA-241	NA									
	Elbow 1/4 FFL x 1/4 MFL (1), DD12CA-051	NA									
	Fitting 1/4 FFL x 1/4 FPT (1), 5H40-5872	NA									